

Series 400

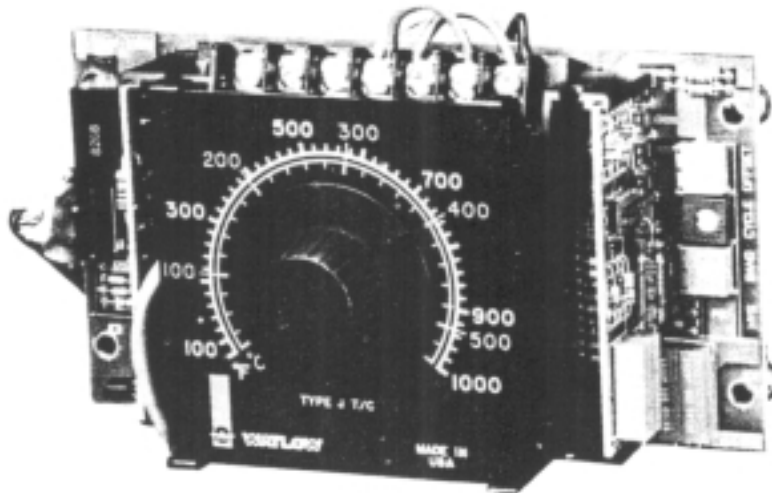

Time Proportioning Temperature Control

User's Manual



WATLOW

Watlow Controls, 1241 Bundy Blvd., Winona, MN 55987 507/454-5300, Fax: 507/452-4507

W400-DA20-9038
September, 1990
Supersedes:
W400-DA10-8922

\$5.00
Made in the U.S.A.

General Description

The Watlow Series 400 is an open board temperature control. The control mode is ON/OFF, time proportioning or full PID. The input for the Series 400 is a single thermocouple, RTD, or thermistor sensor input. The output device can be a mechanical relay, switched DC voltage, solid state relay, process output, or Mercury Displacement Relay (MDR) driver. Set point options include a remote or integral setpot assembly.

Specifications

Control Mode

- ON/OFF.
 - Sensitivity adjust: Typically 1° to 10° switching hysteresis. 0.1 to 1.0 for tenths ranges.
- Time proportioning with manual reset.
 - Proportional band adjust: typically 5 to 100°F/°C. 0.5 to 10 for tenth ranges.
 - Cycle time adjust: typically 1 to 25 seconds.
 - Manual reset adjustable over 100% of the proportional band.
- PID: Proportional with auto reset and rate (integral and derivative).
 - Proportional band: Typically 5 to 100°F/°C. 0.5 to 10 for tenth ranges.
 - Reset: Typically 0.20 to 2.5 repeats per minute.
 - Rate: Typically 0 to 1.7 minutes per repeat.
 - Cycle time: Typically 1 to 25 seconds.

Operator Interface

- Setpot.
 - Dial scale calibrated to compensate for sensor non-linearities.
 - Dual °F & °C scales.
 - Remote or on-board mounting.
 - Remote programmer also available.
 - Fixed set point available.
- Temperature display.
 - Optional remote digital display may be added any time.

Input

- Thermocouple, thermistor, or RTD available.
- Thermocouple may be isolated or grounded.
- Thermocouple, automatic cold junction compensation.
- RTD input 2 or 3 wire, platinum 100Ω @ 0°C calibrated for #3916 (JIS): 0.003916Ω/Ω°C.
- T/C and RTD sensor break protection de-energizes output to protect system.
- Lead resistance effect for type J, K, or T thermocouple input: 200Ω of lead resistance will cause less than 1°F error. Refer to the lead wire manufacturer's specification on ohms per double foot for type and gauge of wire.
- Shorted thermistor de-energizes the output.
- Open thermistor energizes the output

Output

- Relay, Electro-mechanical, SPDT, 6A @ 120/240VAC.
- Solid State Relay, 0.5A @ 24 VAC min., 264 VAC max., opto-coupled, zero-crossed switching. Minimum off state impedance is 20MΩ.
- Switched DC, 1KΩ load @ 10mA min. 500Ω minimum allowable load impedance.
- Solid State Relay, 0.5A @ 24 VAC min., 264 VAC max., opto-coupled zero-crossed switching.
- Process output, 0-20mA and 4-20mA, load impedance: 600Ω maximum.
- Process output, 0-5V and 1-5V, load impedance: 500Ω minimum.

Accuracy

- Calibration Accuracy and Sensor Conformity: ± 1% of span, at 77°F ± 5°F (25°C ± 3°C) ambient and rated line voltage + 10% -15%.
- Setpot Assy: ± 2.5% of dial scale.
- Accuracy Span: 1000°F or 540°C minimum ± 2.5% of range (whichever is greater).
- Temperature Stability: Typically ±5μV / °F ambient for thermocouple. Typically <1°F from 32 to 130°F for RTD and thermistor.
- Voltage Stability: ± 0.01% of span / % of rated line voltage.

Agency Approvals

- UL recognized, file #E43684, UL873, UL197.

Terminals

- #6 compression type screws on barrier strip.

Power

- 120/240VAC, -15%, +10%, 47 to 63Hz.
- 100/200VAC, -15%, +10%, 47 to 63Hz.
- 12/24VAC, -15%, +10%, 47 to 63Hz.
- 6 VA power consumption.

Operating Environment

- 30 to 130°F/0 to 55°C.
- 0 to 90% RH, non-condensing.
- Storage Environment: -40 to 158°F/-40 to 70°C.

Dimensions

Control

- | | | |
|-----------|----------|----------|
| • Length: | 6.0 in. | (152 mm) |
| • Width: | 3.25 in. | (83 mm) |
| • Height: | 2.75 in. | (70 mm) |
| • Weight: | 0.79 lb. | (0.36kg) |

Setpot Assembly

- | | | |
|------------------------|-----------|----------|
| • Dial scale: | 3 in. sq. | (76 mm) |
| • Pot depth behind: | 0.6 in. | (15 mm) |
| • Knob depth in front: | 0.7 in. | (18 mm) |
| • Lead length: | 24 in. | (610 mm) |
| • Weight: | 0.15 lb. | (0.66kg) |

Control

Series 400 = ON/OFF, time proportioning or full PID temperature control. Remote or integral setpot. T/C, RTD, or thermistor input.

Control Mode

- 1 = ON/OFF
- 2 = TP/MR
- 8 = PID

Output Type

- B = Solid State Relay with contact suppression using resistive loads.
- C = DC Output (Open collector)
- D = Relay, Mechanical 6A, Form C
- F = 4-20mA
- G = 0-20mA
- H = 0-5 VDC
- J = 1-5VDC
- K = Solid State Relay without contact suppression using inductive loads.

Set Pot

- 0 = Integral/Remote setpot included
- 1 = No setpot included

Input

RTD

100 =	0	to	600°F	or	-17.8	to	315°C	JIS
101 =	-17.8	to	315°C	or	0	to	600°F	JIS
102 =	0.0	to	199.9°F	or	-17.8	to	93.3°C	JIS
103 =	-17.8	to	93.3°C	or	0.0	to	199.9°F	JIS

Thermistor

300 =	0.0	to	140.0°F	or	-17.8	to	60.0°C	300Ω (800-010)
301 =	0.0	to	250.0°F	or	-17.8	to	121.1°C	3KΩ (800-012)
302 =	200	to	600°F	or	93.3	to	315°C	100KΩ (800-016)

Thermocouple

600 =	75	to	999°F	or	24	to	537°C	"J"
601 =	24	to	537°C	or	75	to	999°F	"J"
602 =	0	to	2000°F	or	-17.8	to	1093°C	"K"
603 =	-200	to	600°F	or	-129	to	315°C	"T"
604 =	75	to	250°F	or	24	to	121°C	"J"
605 =	75	to	500°F	or	24	to	260°C	"J"

Line Voltage

- 0 = 120/240 VAC
- 1 = 100/200 VAC
- 2 = 12/24 VAC

Accessories

- Remote digital display: D400-1002-0200 Push-to-read set point switch.
D400-0002-0200 Display process only.

4.0 - - - 0.0.0

Installation

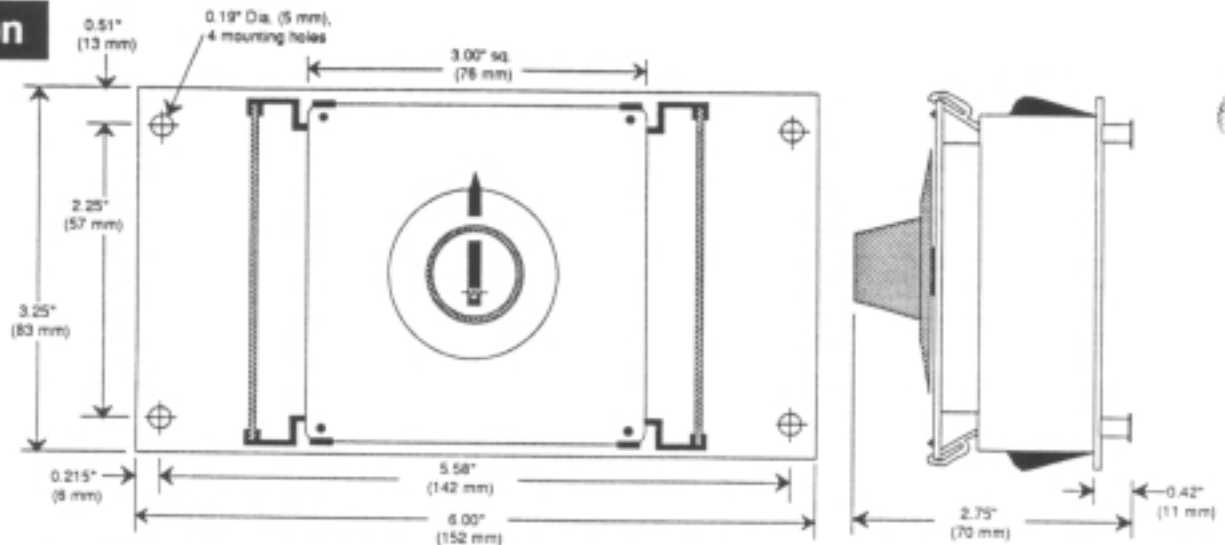

Figure 1 - Series 400 Dimensions

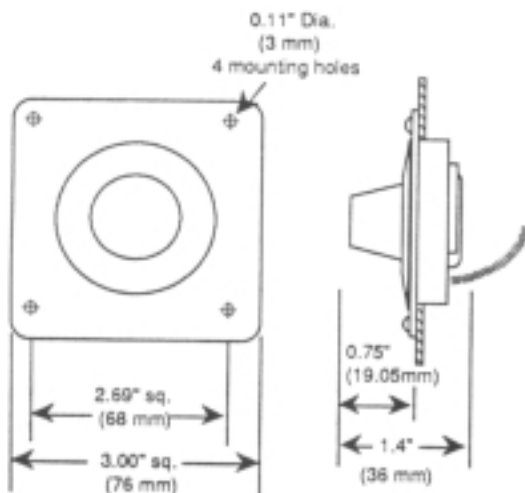

Figure 2 - Setpot Dimensions

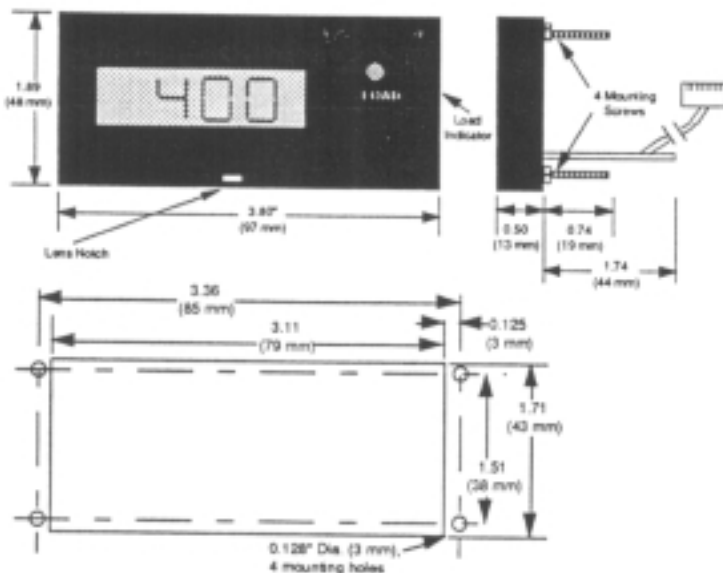

Figure 3 - Digital Display Dimensions & Panel Cutout

Mounting the Series 400

1. Drill four 0.19" (5 mm) diameter holes in desired panel location using the control as a template. See Figure 1.
2. Mount the Series 400 with four screws.
3. Wire the control per Figure 4 or 5 on Page 5.
4. Connect the sensor, load, and line cord. See Pages 5 through 10.
5. Optional Snaptrak mountable.

Mounting the Digital Display

1. Drill four 0.128" (3 mm) diameter holes in desired panel location using the indicator as a template. See Figure 3.
2. Mount the Display Indicator with four screws.
3. Plug the connector into the Series 400 control.

Installing the Remote Setpot Assembly:

1. Remove the setpot dial scale from the Series 400. Press the four setpot mounting clips away from the dial plate. The setpot lead wire is coiled around the back of the setpot assembly.
2. Drill 2.25" (60 mm) diameter hole (or use a 2.25", 2.375", 2.50", or 2.675" punch) at desired remote setpot assembly location. See Figure 2.
3. Using the dial scale as a location template, center and mark all four mounting holes on the dial scale with a center punch.
4. For a bolted dial scale assembly, drill four 0.125" (3 mm) diameter clearance holes. If you are using a screw assembly, use a tap drill. Tap drill sizes used are:

Tap drill size	for	Screw/thread size
#43 - 0.089 dia.		#4-40
#42 - 0.093 dia.		#4-48

5. Drill four 0.189" (5 mm) diameter holes in desired panel location. See Figure 1.



WARNING:

To avoid potential electric shock, use National Electric Code safety practices when wiring and connecting this unit to a power source and to electrical sensors or peripheral devices.

All wiring and fusing should conform to the National Electric Code and to any locally applicable codes also.



NOTE:

Place one jumper between screw terminals 1 and 3, and another jumper between screw terminals 2 and 4.

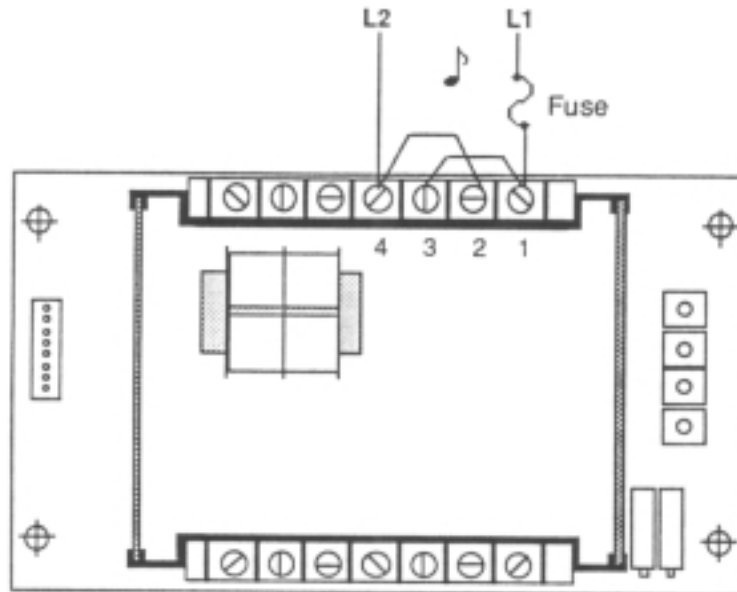

Figure 4 - 120, 100, and 12 VAC Power Wiring.
(determined by your model number)



NOTE:

Place a jumper between screw terminals 2 and 3.

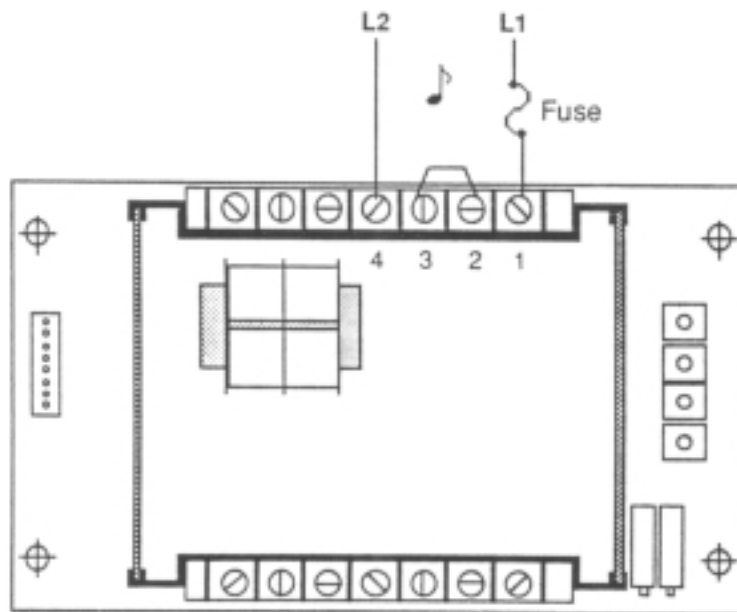

Figure 5 - 240, 200, and 24 VAC Power Wiring.
(determined by your model number)

Input Wiring

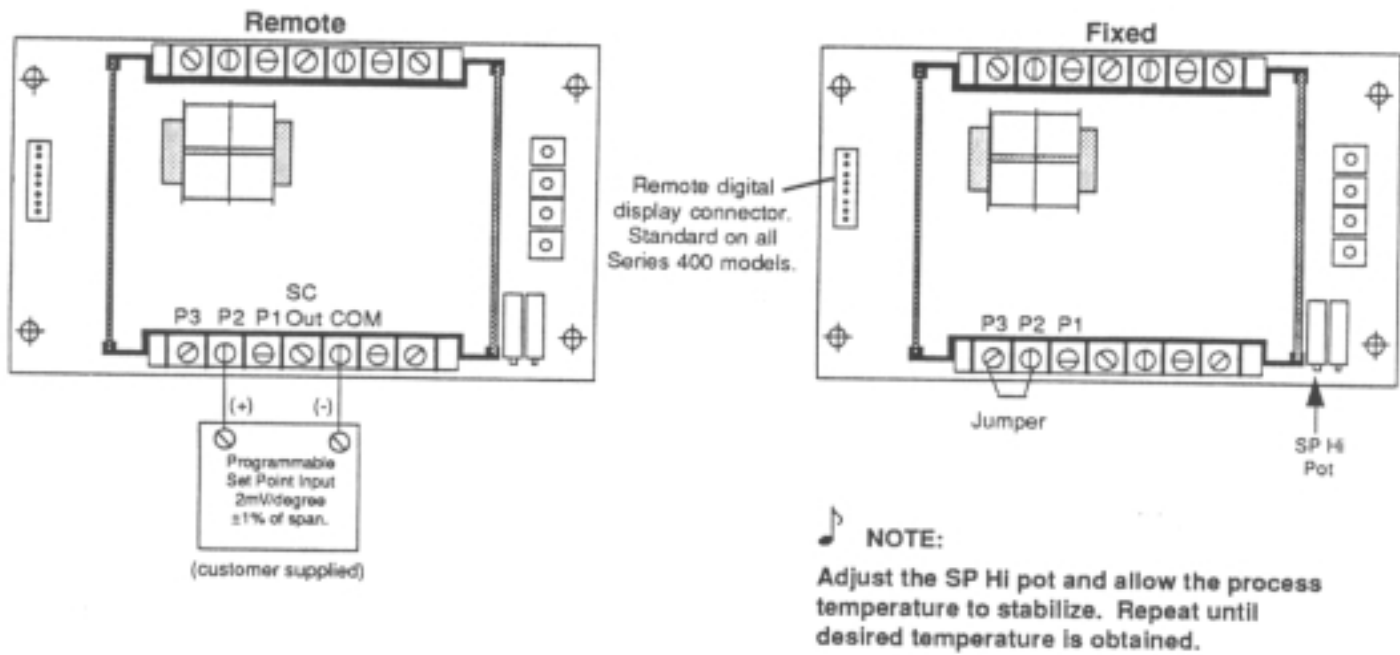

Figure 6 - Remote/Fixed Setpot Wiring

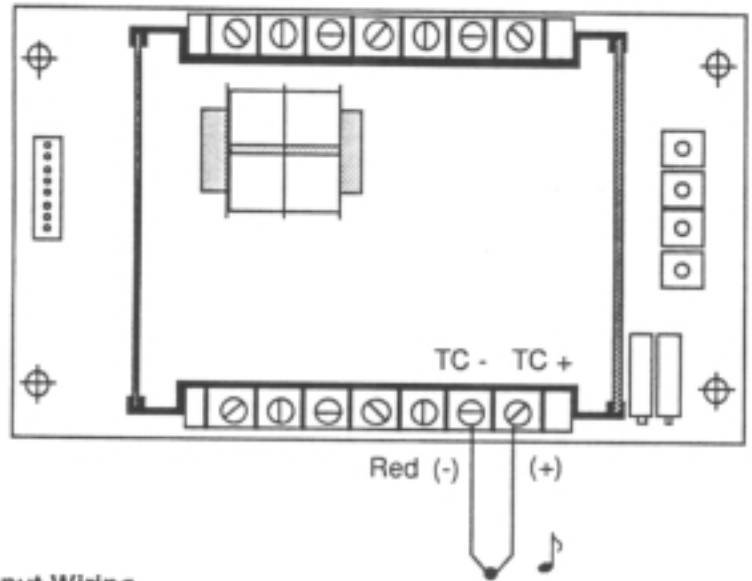

Figure 7 - Thermocouple Input Wiring

NOTE:
You must use an isolated or ungrounded thermocouple if an external monitoring device with a non-isolated circuit common is connected to the millivolt output. Extension wire for thermocouples must be of the same alloy as the thermocouple itself to limit errors.

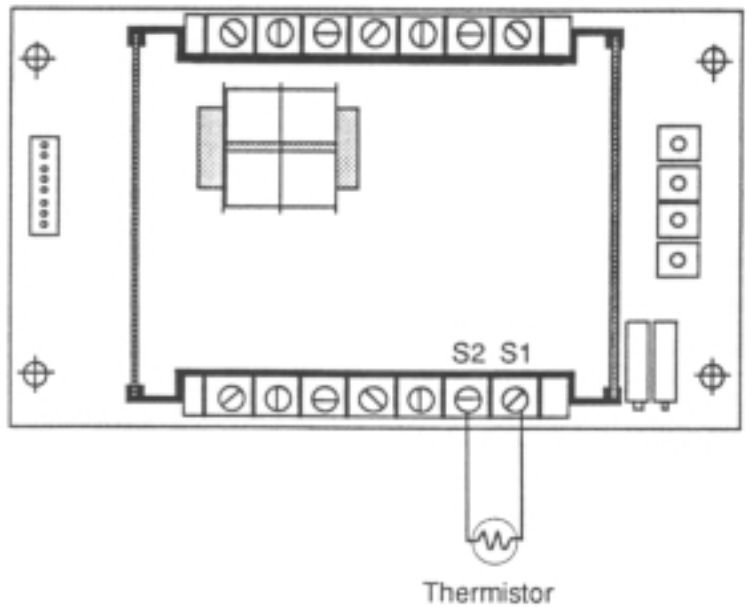

Figure 8 - Thermistor Input Wiring

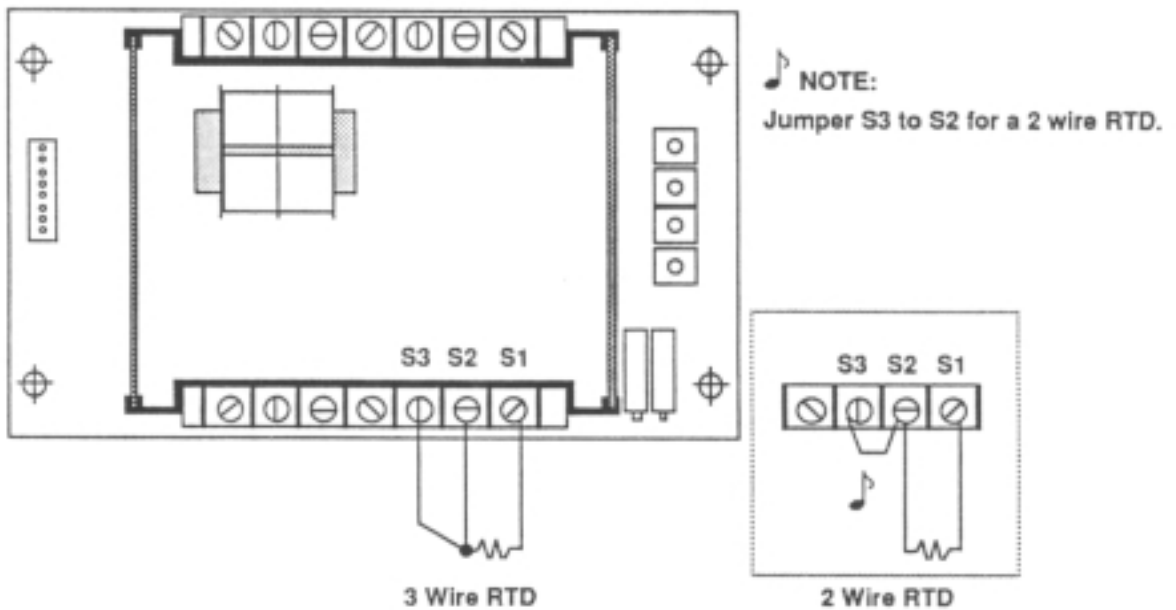

Figure 9 - 2 or 3 Wire RTD Input

NOTE:

Long lead lengths create electrical resistance. There will be approximately +2°C input error for every 1Ω of lead length resistance, when using a two wire RTD. That resistance, when added to the resistance of the RTD element, can result in erroneous input to the instrument. To overcome this problem, use a three wire RTD sensor, which compensates for lead length resistance. When extension wire is used for a three wire RTD, all three extension wires must have the same electrical resistance. (i.e. same gauge, copper stranded.)

Output Wiring

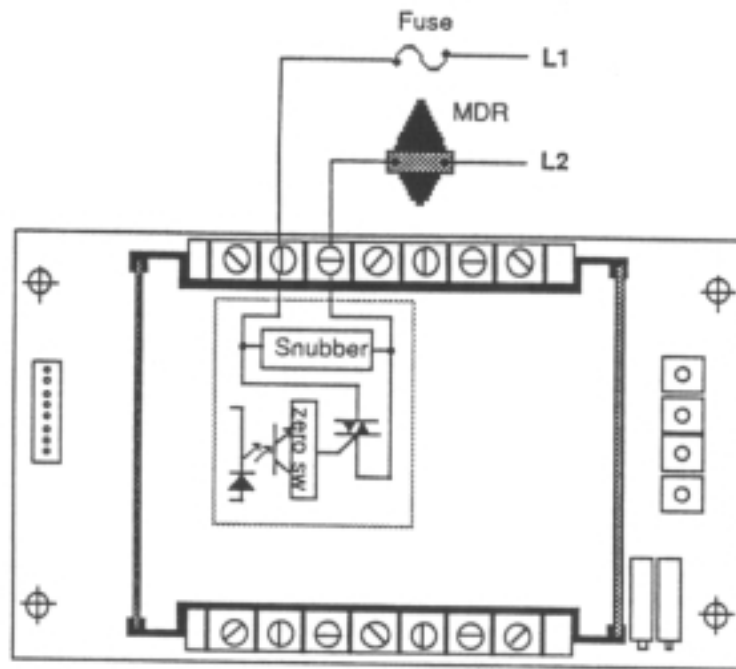

Figure 10 - Solid State Relay with Suppression (40XB-XXXX-X000)

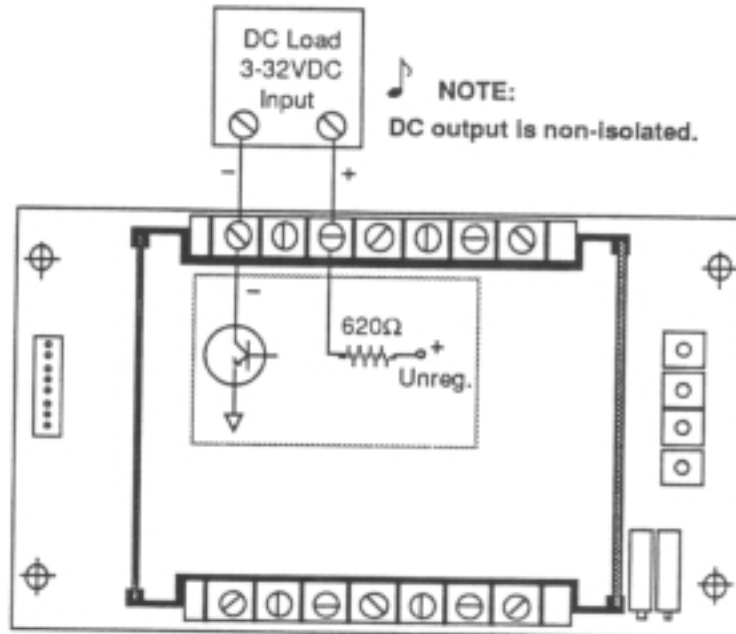

Figure 11 - DC Output (Open Collector), (40XC-XXXX-X000)

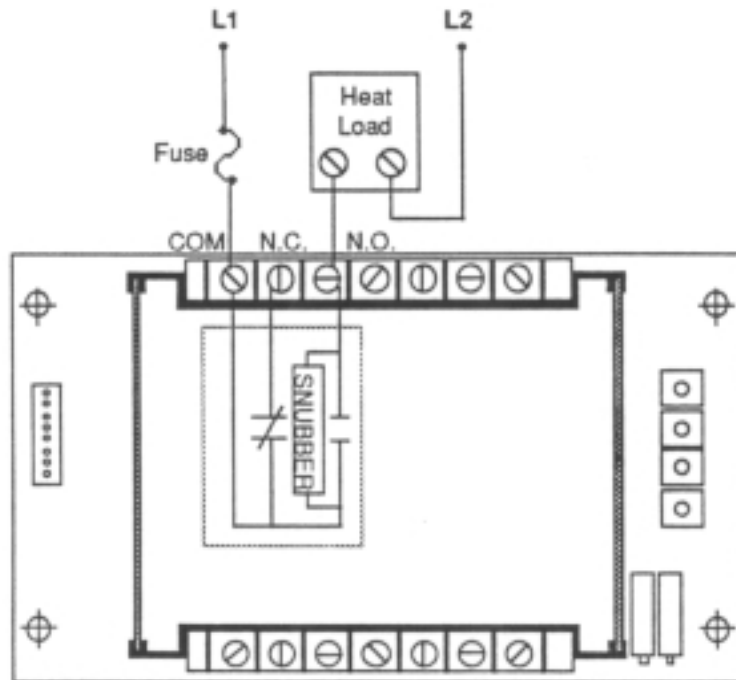

Figure 12 - 6 Amp Mechanical Relay (40XD-XXXX-X000)

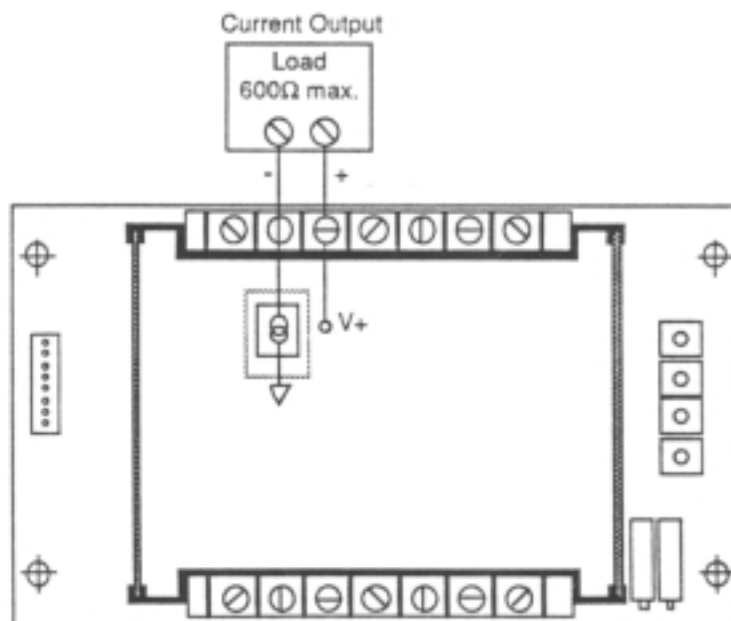

Figure 13 - 4-20/0-20mA Output (40XF or 40XG-XXXX-X000)

Output Wiring (cont.)

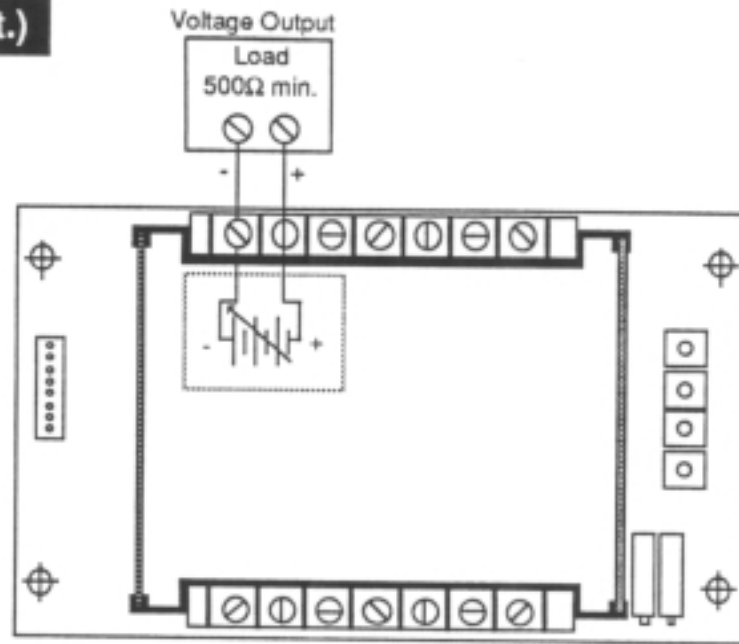

Figure 13 - 0-5/1-5VDC Output (40XH or 40XJ-XXXX-X000)

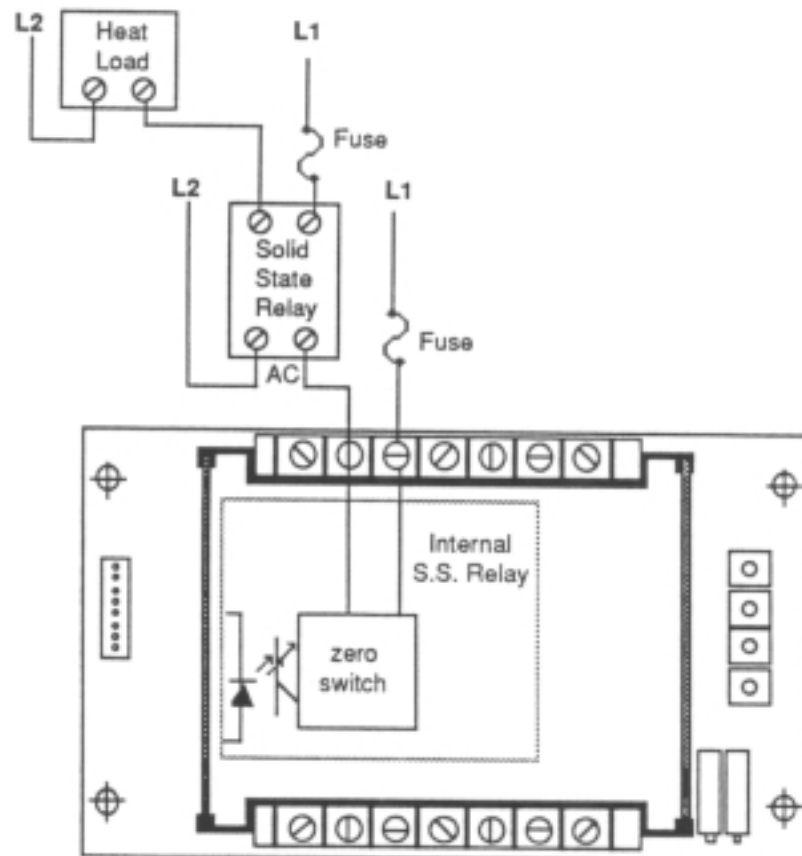

Figure 14 - Solid State Relay Driver without Suppression (40XK-XXXX-X000)

System Wiring Example



WARNING:

Install high or low temperature limit control protection in systems where an overtemperature or undertemperature fault condition could present a fire hazard or other hazard. Failure to install temperature limit control protection where a potential hazard exists could result in damage to equipment and property, and injury to personnel.



CAUTION:

With Watlow mercury relays, load must have a unity power factor. For RESISTIVE LOADS ONLY.

NOTE:

All fuses must be selected for proper protection in a given application.

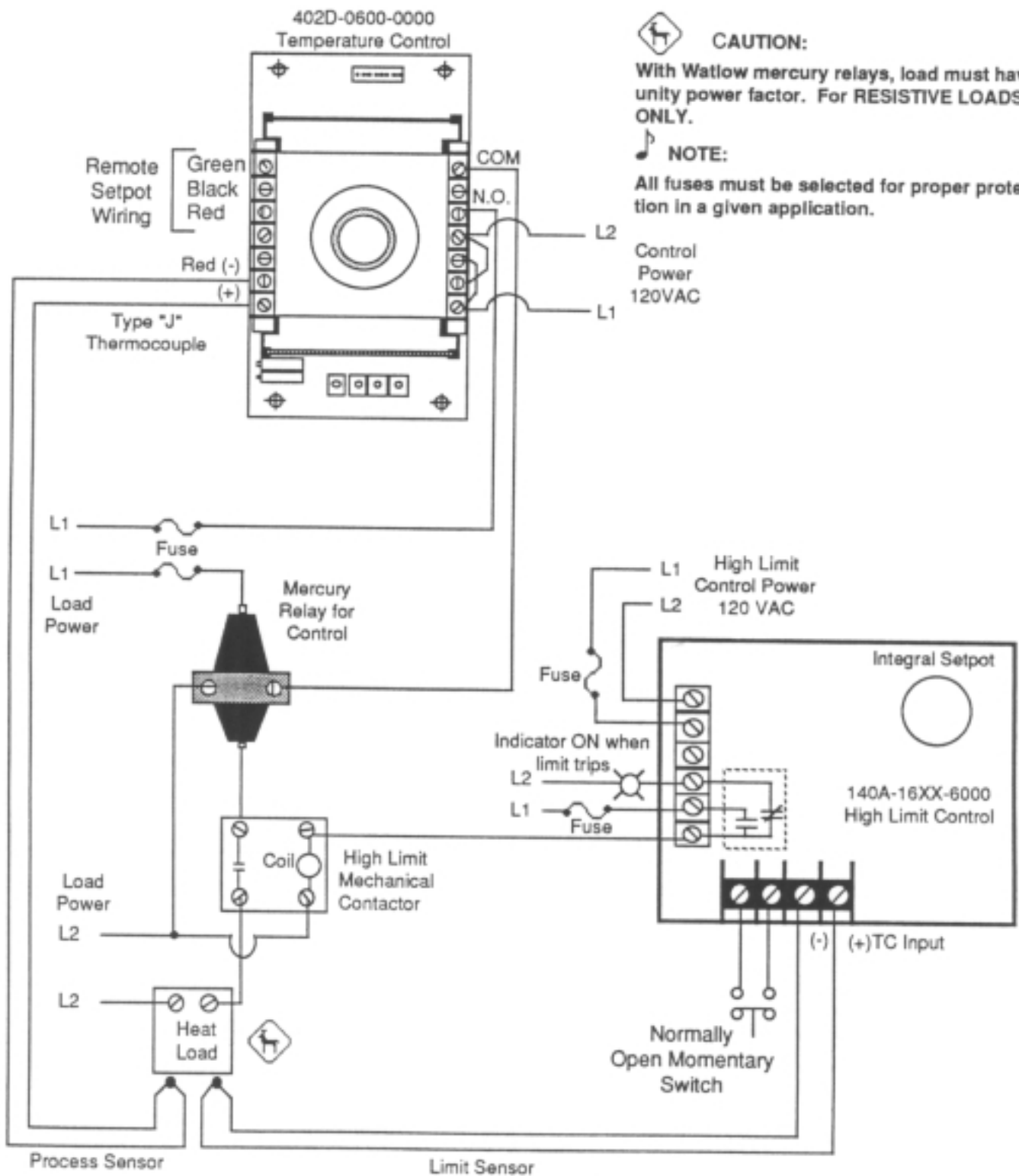

Figure 15 - Series 400 System Wiring Example

Tuning

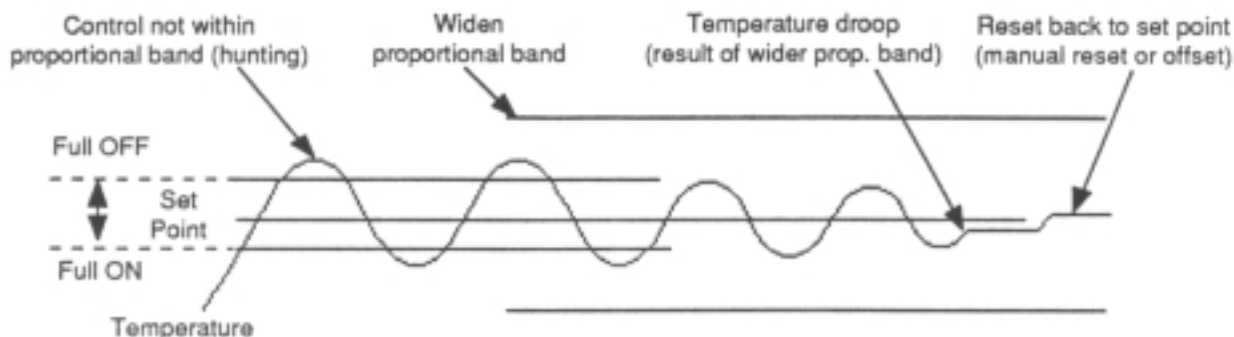

Figure 16 - Adjustment Graph

Tuning Procedure for ON/OFF Control with Sensitivity (Model 401)

Initial Settings:

1. Switching sensitivity: Turn to mid-range.

Energize the system and allow to stabilize. When stable, the load will cycle at a constant rate.

Switching Sensitivity Adjustment:

May be adjusted from 1°F/°C to 10°F/°C, for tenth degree ranges, 0.1°F/°C to 1.0°F/°C. Set the sensitivity adjustment maximum CCW if a narrow temperature differential is desired. Adjust the sensitivity maximum CW (clockwise) to increase the life of a mechanical contactor if the temperature differential is not critical.

Tuning Procedure for Time Proportioning Controls with Manual Reset (Model 402)

The setup procedure for most applications does not require the full **Tuning Procedure for Time Proportioning Controls with Manual Reset**, if the following settings provide satisfactory control.

1. Proportional Band: Mid-range.
2. Cycle Time: Counterclockwise (CCW) if using solid state power switching devices. Mid-range to clockwise (CW) if using mechanical power switching devices.
3. Reset: Set to mid-range. If actual temperature is below or above set point refer to manual offset adjustment below.

If the parameter values above do not provide satisfactory control, refer to the full tuning procedure following.

Initial Settings:

1. Proportional Band: Turn maximum CW (widest setting).
2. Manual Offset: Turn to mid-range.
3. Cycle Time: Turn maximum CCW (fastest time).

Energize the system and allow the process temperature to stabilize. When the system is stable, the load will cycle at a constant rate.

Proportional Band Adjustment:

Rotate the proportional band pot CCW 1/4 turn, observe system stability. Allow enough time for the system to stabilize. Repeat until the process temperature begins to hunt (becomes unstable). When hunting is observed, rotate the pot slowly CW until the system becomes stable. Some systems may be stable enough to allow minimum proportional band setting (maximum CCW).

Manual Offset:

In virtually all proportional control systems, the average process temperature may drop or rise to a point that is not the set point temperature. This action takes place even though the process temperature has stabilized.

Adjust the offset pot slowly CW if the process temperature stabilizes below set point temperature. Adjust CCW if the process temperature stabilizes above set point temperature. If large changes in set point temperature are made, readjustment of the manual reset may be required.

Cycle Time:

Set as required. Best control is always achieved with faster cycle times. However, if a mechanical contactor or solenoid is used to switch power to the load, slower cycle times may be desirable to minimize the wear on the mechanical components.

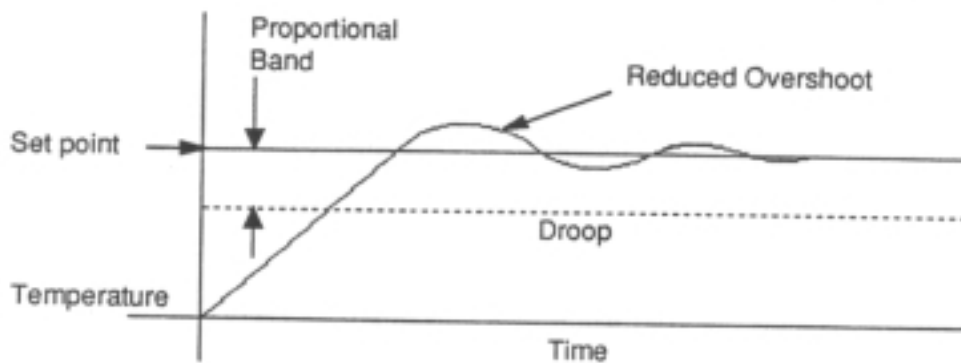

Figure 17 - PID Adjustment Graph

Tuning Procedure for PID Controls
(Model 408)

Initial Settings:

1. Cycle time: 1 seconds; turn maximum counterclockwise; CCW.
2. Proportional band: Widest band; turn maximum clockwise; CW.
3. Rate: 0; turn maximum CCW.
4. Reset: 0.2 repeats/minute; turn maximum CW.

Energize the system and allow the process temperature to stabilize. When the system is stable, the load will cycle at a constant rate.

After an adjustment is made, the system may become unstable. Allow sufficient time for the system to stabilize before making another adjustment.

Proportional Band Adjustment:

Rotate the proportional band pot CCW 1/4 turn and observe system stability. Repeat until the process temperature begins to hunt (becomes unstable). When hunting is observed, rotate the pot CW, in small increments, until the system becomes stable. Some systems may be stable enough to allow minimum proportional band (maximum CCW).

Rate Adjustment:

The rate adjustment controls overshoot as load temperature approaches set point temperature by limiting the rate of change of load temperature. Rotate the rate pot 1/4 turn CW. Change the set point temperature 20 to 30°F/°C and observe the approach to set point.

If the load temperature overshoots, repeat the procedure until optimum approach to set point is achieved. If the rate pot is advanced too far, the system will be overdamped and approach to set point will be very sluggish.

Reset Adjustment:

The reset adjustment controls the time required to drive the error signal to zero. A low setting (0.2 repeats/minute) requires long periods of time for the load temperature to reach set point. If the reset time is set too fast (2.5 repeats/minute) the system may become unstable and oscillate about set point temperature.

To adjust reset time, rotate the reset pot 1/4 turn CCW and observe stability. Continue adjusting CCW until the system becomes unstable. Rotate CW very slowly to regain stability.

Cycle Time:

Cycle time is the time base used in proportioning power to the load. At a setting of 2 seconds, if 25% power is required to maintain load temperature at set point, power will be applied for 0.5 seconds every 2 seconds. At a 10 second cycle time, power would be applied for 2.5 seconds every 10 seconds.

Best control is always achieved with faster cycle times. However, if a mechanical contactor or a solenoid is used to switch power to the load, slower cycle times may be desirable to minimize the wear on the mechanical components.

Glossary

1. **ON/OFF** - The output is turned full ON below set point and stays turned on until the process temperature reaches set point, then the controller turns the output full OFF. At this point, depending on the design of the thermal system, the process temperature overshoots the set point temperature by some degree. As the load cools down below set point (an amount equal to the switching sensitivity or differential) the output is once again turned full ON.
2. **Switching Sensitivity or Differential** - The output will de-energize when the actual temperature reaches the set point temperature. The switching sensitivity or differential is the drop in temperature (°F/°C) required to re-energize the output.
3. **Proportional Band** - In a straight time proportional control system when the actual process temperature is below set point and outside the proportional band limit, 100% power is applied to the load.

When the actual process temperature is above set point and outside the proportional band limit, 0% power is applied to the load.



When the actual process temperature is within the proportional band, the controller will proportion the amount of power applied to the load, 0 to 100%.

4. **Temperature Droop** - Phenomenon that occurs in a proportional control system without reset. As the proportional band is increased, the average process temperature may drop to a point that is not the set point temperature. This action takes place even though the load has stabilized.
5. **Manual Reset or Offset** - Adjustment used in control systems to offset any temperature droop and obtain agreement between actual process temperature and controller set point.
6. **Time Proportioning with Manual Reset** - The output is turned full ON until the process temperature reaches the proportional band. Once in the proportional band the output is cycled ON/OFF in proportion to the degree of difference between actual process temperature and controller set point.

When the process temperature is just entering the proportional band the output may cycle 90% ON and 10% OFF. When the process temperature is near set point the output may cycle 10% ON and 90% OFF. When the process temperature is above the proportional band the output is turned full OFF.

After the system has stabilized a phenomenon occurs in a proportional control system called droop. This happens in virtually all proportional control systems. The manual reset adjustment is used to compensate for any temperature droop and obtain agreement between set point temperature and desired actual process temperature.

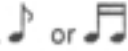
7. **Temperature Oscillation or Hunting** - Occurs when the proportional band is too narrow or the system is upset by some outside source. The actual process temperature is not controlled within the proportional band on its extreme temperature excursions.

Load temperature may never stabilize. Control is either full ON or full OFF, not within the proportional band.
8. **Cycle Time** - Time interval between consecutive turn ons.
9. **Zero Switching** - Load is activated only during the time period that the sine wave is going through zero. This eliminates RFI and EMI radiation (applies to solid state outputs only).
10. **Automatic Reset (Integral)** - Used in proportional control systems to automatically pick up any system droop. Normally this action is adjustable and adjusts the time for reset to obtain agreement between actual process temperature and controller set point.
11. **Rate (Derivative)** - Action that anticipates the rate of actual process temperature rise and automatically widens the proportional band to prevent overshoot. Returns the proportional band to the static adjustment when the set point temperature is stable within the static band boundaries.
12. **Anti Reset** - Inhibits reset action when the actual process temperature is outside the proportional band.
13.  - Musical Notes are used to alert you to important details.
14.  - The Stop Sign alerts you to a "WARNING", a safety hazard which could affect you and the equipment.
15.  - The Deer Crossing Sign alerts you to a "CAUTION", a safety or functional hazard which could affect your equipment or its performance.

RTD Field Calibration Procedure

40XX-X10X-X000

Equipment Required:

- 100Ω decade resistance box.
- Digital Voltmeter.

Setup:

1. Wire your unit for the correct line voltage and connect the remote setpot, if not already connected. See line voltage wiring, Page 5, Figure 4 or 5. See Page 11 for setpot wiring.
2. Connect the decade resistance box to S1 and S2 terminals on the control. Place a jumper between S2 and S3. See Page 7. Check the stickers above the terminals for proper location.
3. Connect the DVM (+) to SC, and DVM (-) S3. Again, check the stickers above the terminals for proper location. Apply power.

NOTE: See Table 1 for values that apply to your unit's range code. See Figure 18 on Page 16 and Figure 19 on Page 17 for potentiometer location.

Procedure:

1. Set the decade box to _____ Low ohms. Adjust the SC Lo pot for _____ SC Lo volts on the DVM.

2. Set the decade box to _____ High ohms. Adjust the SC Hi pot for _____ SC Hi volts on the DVM.
3. Repeat Steps 1 and 2 until no further adjustment is necessary.

Setpot Calibration

1. Move DVM (-) to the Blk terminal under the setpot wiring. Check the stickers above the terminals.
2. Turn the setpot dial to the low end of the scale (low temperature). Set the decade box to _____ Low ohms. Adjust the SP Lo pot for 0.00 volts on the DVM.
3. Turn the setpot dial to the high end of the scale (high temperature). Set the decade box to _____ High ohms. Adjust the SP High pot for 0.00 volts on the DVM.
4. Repeat Steps 2 and 3 as necessary until no further adjustment is needed.
5. Set the decade box to Mid mV. Turn the setpot dial until the DVM reads 0.00. The dial should be at Mid point on the scale ±1 minor division.

Table 1 - RTD Input Calibration Values (JIS curve 0.003916)

Range		Millivolt vs. Temperature								
Code	Low/High	Cal Curve	Low Ohms	SC Lo Volts	Low Temp	Mid Ohms	Mid Temp	High Ohms	SC Hi Volts	High Temp
100	0 to 600°F	#3916	92.93Ω	0.000V	0°F	157.88Ω	300°F	219.58Ω	1.200V	600°F
101	-17.8 to 315°C	#3916	92.93Ω	-0.036V	-17.8°C	158.30Ω	150°C	219.58Ω	0.630V	315.6°C
102	0.0 to 199.9°F	#3916	92.93Ω	0.000V	0.0°F	114.93Ω	100.0°F	136.59Ω	4.000V	200.0°F
103	-17.8 to 93.3°C	#3916	92.93Ω	-0.356V	-17.8°C	115.81Ω	40.0°C	136.59Ω	1.866V	93.3°C

Thermistor Calibration Procedure

40XX-X30X-X000

Equipment Required:

- Digital voltmeter (DVM).
- Appropriate decade box dependent on range.

Setup:

1. Wire your control for correct line voltage and connect the remote setpot, if not already connected. See line voltage wiring, Page 5, Figures 4 or 5. See Page 11 for setpot wiring.
2. Connect the decade box to the S1 and S2 terminals. See Page 7.
3. Connect the DVM (+) to SC, and DVM (-) to COM. Check the stickers above the terminals for proper location. Apply power.

NOTE: Refer to Figure 18 below, and 19 (on facing page) for potentiometer locations, and to Table 2 below for proper range values.

Procedure:

1. Set the decade box to _____ Low ohms. Adjust the SC Lo pot for _____ SC Lo volts on the DVM.

2. Set the decade box to _____ High ohms. Adjust the SC Hi pot for _____ SC High volts on the DVM.
3. Repeat Steps 1 and 2 until no further adjustment is necessary.

Setpot Calibration

1. Move DVM (-) to the Blk terminal under the setpot wiring. Check the stickers above the terminals.
2. Turn the setpot dial to the low end of the scale (low temperature). Set the decade box to _____ Low ohms. Adjust the SP Lo pot for 0.00 volts on the DVM.
3. Turn the setpot dial to the high end of the scale (high temperature). Set the decade box to _____ High mV. Adjust the SP Hi pot for 0.00 volts on the DVM.
4. Repeat Steps 2 and 3 as necessary until no further adjustment is necessary.
5. Set the decade box to _____ Mid mV. Turn the setpot dial until the DVM reads 0.00. The dial should be at Mid point on the scale ± 1 minor division.

Table 2 - Thermistor Input Calibration Values

Range			Millivolt vs. Temperature							
Code	Low/High	Thermistor Code	Low Ohms	SC Lo Volts	Low Temp	Mid Ohms	Mid Temp	High Ohms	SC Hi Volts	High Temp
300	0.0 to 140.0°F	#10-300Ω	1647Ω	0.000V	0.0°F	344.6Ω	70.0°F	98.4Ω	2.800V	140.0°F
301	0.0 to 250.0°F	#12-3KΩ	25620Ω	0.000V	0.0°F	1127Ω	120.0°F	113.4Ω	5.000V	250.0°F
302	200 to 600°F	#16-100KΩ	6909Ω	0.400V	200°F	389.7Ω	400°F	54.87Ω	1.200V	600°F

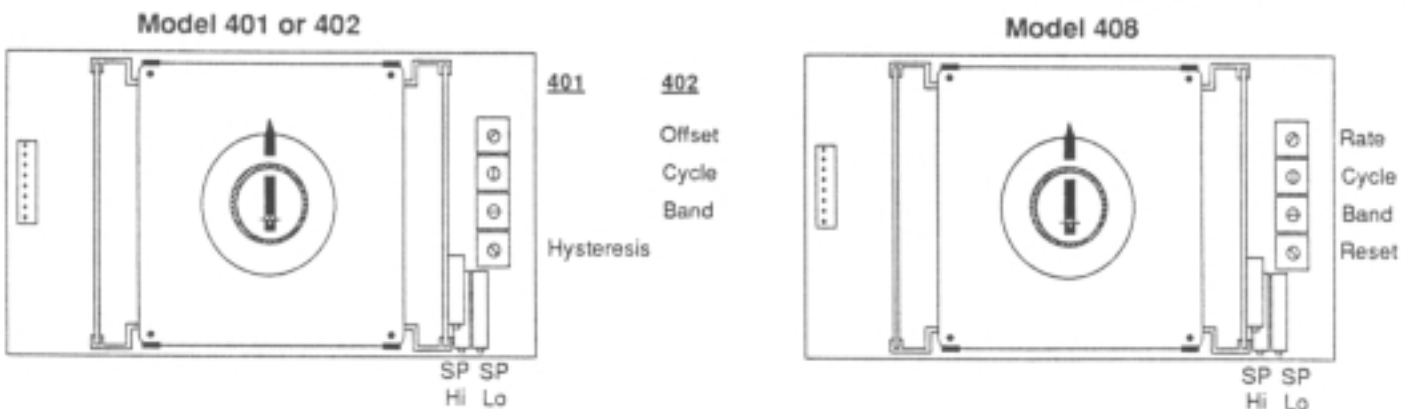

Figure 18 - Series 400 Potentiometer Locations (Top View)

40XX-X60X-X000

Equipment required:

- Digital voltmeter (DVM).
- Precision millivolt source (mV source).
- Appropriate type reference compensator with reference junction at 32°F/0°C.
- Watlow Hand-Held Digital Indicator (Series 64) and calibration leads may be used in place of millivolt source and reference compensator. For Type "J": Series 64 - #6406-00C1-0601 and Calibration Leads #A001-0050-0000. For Type "K": Series 64 - #6406-00C1-0602 and Calibration Leads #A001-0064-0000.

Setup:

1. Wire your control for the correct line voltage and connect the remote setpot, if not already connected. See line voltage wiring, Page 5, Figure 4 or 5. See Page 11 for setpot wiring.
2. Connect the millivolt source to the T/C reference compensator, and the compensator to the T/C input terminals on the control. See Page 6, Figure 7. For the Series 64, connect the T/C output to the T/C input on the control.
3. Connect the DVM (+) to SC, and DVM (-) to COM. Check the stickers above the terminals for proper location. Apply power.

NOTE:

See Table 3 for values that apply to your unit's range code. See Figure 18 on the facing page, and 19 below for potentiometer locations.

Table 3 - T/C Input Calibration Values

Range			Millivolt vs. Temperature							
Code	Low/High	T/C Type	Low mV	Low Volts	Low Temp	Mid mV	Mid Temp	High mV	High Volts	High Temp
600	75 to 999°F	"J"	1.22mV	0.150V	75°F	14.11mV	500°F	29.52mV	2.000V	1000°F
601	24 to 537°C	"J"	1.22mV	0.048V	24°C	16.33mV	300°C	29.52mV	1.076V	538°C
602	0 to 2000°F	"K"	-0.692mV	0.000V	0°F	22.25mV	1000°F	44.86mV	4.000V	2000°F
603	-200 to 600°F	"T"	-4.15mV	-0.400V	-200°F	6.65mV	300°F	15.77mV	1.200V	600°F
604	75 to 250°F	"J"	1.22mV	0.150V	75°F	4.16mV	175°F	6.42mV	0.500V	250°F
605	75 to 500°F	"J"	1.22mV	0.150V	75°F	7.95mV	300°F	14.11mV	1.000V	500°F

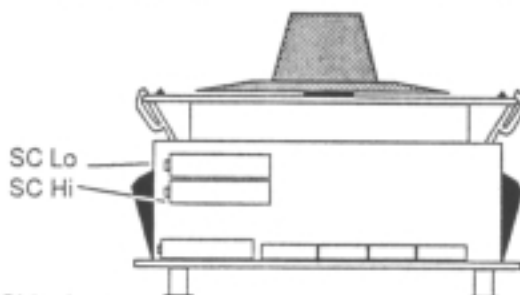

Figure 19 - Potentiometer Locations (Sideview)

T/C Field Calibration Procedure

Procedure:

1. Set the MV source to _____ Low mV value (or Low °F on Series 64). Turn the setpot to Low Temp (°F). Adjust the SC Lo pot for _____ SC Lo volts on the DVM.
2. Set the MV source to _____ High mV (or high °F on Series 64). Adjust the SC Hi pot for _____ SC High volts on the DVM.
3. Repeat Steps 1 and 2 as necessary until no further adjustment is needed.

Setpot Calibration

1. Move DVM (-) to the Blk terminal under the setpot wiring. Check the stickers above the terminals.
2. Turn the setpot dial to the low end of the scale (low temperature). Set the mV source to _____ Low mV. Adjust the SP Lo pot for 0.00 volts on the DVM.
3. Turn the setpot dial to the high end of the scale (high temperature). Set the MV source to _____ High mV. Adjust the SP Hi pot for 0.00 volts on the DVM.
4. Repeat Steps 2 and 3 as necessary until no further adjustment is needed.
5. Set the MV source to _____ Mid mV. Turn the setpot dial until the DVM reads 0.00. The dial should be at Mid point on the scale ± 1 minor division.

Troubleshooting Chart

Problem	Probable Cause	Action
Poor temperature control.	The control parameters are not adjusted properly.	Adjusting proportional band, cycle time, and manual reset per tuning. See Pages 12-13.
The load will not turn ON.	1. An open sensor.	Repair or replace.
	2. The load circuit is open.	Check the fuses, circuit breakers, load, and wiring. See load wiring, Pages 8 - 11.
	3. A faulty unit.	Consult the factory.
	4. The A.C. input is not connected or is connected improperly.	Check the A.C. input connections. If not present or proper, connect per Line Voltage Wiring. See Page 5, Figure 4 or 5.
The load will not turn OFF.	1. The polarity is reversed on the T/C.	Connect per Input Wiring. See Page 6, Figure 7.
	2. A faulty unit.	Remove power to the control and the control from the system. Apply power to the system with the control removed. If the load turns OFF, return the control to the factory. If the load remains ON, there are other problems in the system that must be resolved. Consult the factory.

Warranty

The Watlow Series 400 is warranted to be free of defects in material and workmanship for 18 months after delivery to the first purchaser for use, providing that the units have not been misapplied.

Since Watlow has no control over their use, and sometimes misuse, we cannot guarantee against failure. Watlow's obligations hereunder, at Watlow's option, are limited to replacement, repair, or refund of purchase price, any parts which upon examination prove to be defective within the warranty period specified. This warranty does not apply to damage resulting from transportation, alteration, misuse or abuse.

Returns

The following procedure applies for any products returned to the factory:

1. You must call Watlow Customer Service, 507/454-5300, for a Return Material Authorization (RMA) number before returning any item for repair. We need this information:
 - Ship-to address
 - Contact name
 - Ship via
 - Symptoms and/or special instructions
 - Name and phone number of person returning the material.
 - Bill-to address
 - Phone number
 - P.O. number

We will not accept a return without an RMA number. The RMA number must appear on the outside of the carton and on all paperwork. Cartons without RMA numbers will be returned. Ship on a freight prepaid basis.

2. You need prior approval and an RMA number from the Customer Service Department when you are returning an unused product for credit. Also, we must apply a 20 percent restocking charge for all returned stock controls and accessories.
3. After we receive your return, we will examine it to determine the cause for your action.
4. In cases of manufacturing defect, we will enter a repair order, replacement order, or issue credit for material.
5. If the unit is unrepairable, we will return it to you with a letter of explanation. Repair costs will not exceed 50 percent of the original cost.

Shipping Claims

When you receive your Watlow control, examine the package for any signs of external damage it may have sustained enroute. If there is apparent damage either outside the box or to its contents, make a claim with the shipper immediately. Save the original shipping carton and the packing material.

Watlow Controls

Watlow Controls is a division of Watlow Electric Manufacturing Company of St. Louis, Missouri. Watlow is an established manufacturer of industrial electric heating products, in business since 1922. Watlow boasts the ability to begin with a full set of specifications and to complete an industrial product that is manufactured totally in-house, in the U.S.A. Products designed and manufactured by Watlow are electric heating elements, sensors, electronic temperature controls and power switching devices.

The Watlow controls operation has been designing solid state electronic control devices since 1962, and has earned the reputation as an excellent supplier to original equipment manufacturers. These OEMs depend upon Watlow Controls to provide compatibly engineered controls which they can incorporate into their products with confidence.

Watlow Controls resides in a 100,000 square foot marketing, engineering and manufacturing facility in Winona, Minnesota.