

BPAC-1
Single Phase

BPAC-3
3 Wire 3 Phase

BPAC-43
4 Wire 3 Phase

The BPAC Power Controllers provide stable, adjustable power, free of RFI (radio frequency interference), to electrical loads. Precise control from 0 to full line voltage is provided by allowing bursts of one or more complete cycles of the 60 cycle power supply into the load. Typical applications are: duct heater control, ovens and furnaces with constant resistance heaters (nichrome, etc.) platens, and die heaters.

The BPAC Power Controller is complete solid state. Zero crossover firing of solid state SCR's supplies power to domestic and commercial loads without RFI (radio frequency interference). Either variable Resistance (135 thru 5000 ohm slide wire) 0-5 VDC, or with the universal range card almost any analog voltage or milliamp control signal, may be used.

SPECIFICATIONS

OUTPUT: 0 to line voltage — in full cycle bursts of line frequency. 0 to rated amperes at maximum voltage.

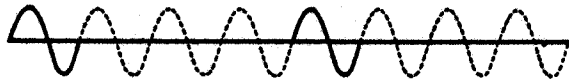

(a) 25% OUTPUT

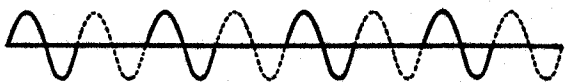

(b) 50% OUTPUT

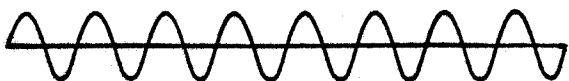

(c) 100% OUTPUT

NOTE: The current is controlled by the load. The BPAC determines the percentage of time the load is energized.

SPECIFICATIONS

MODEL: BPAC-1

VOLTAGE AND FREQUENCY: 120, 208, 240, 277, 480, or 600 volts, 50 or 60 cycle. Single phase.

MODEL: BPAC-3

VOLTAGE AND FREQUENCY: 208, 240, 480, or 600 volts, 50 or 60 cycle. Three phase. Three wire only.

MODEL: BPAC-43

VOLTAGE AND FREQUENCY: 120/208, 220/380, or 277/480 volts, 50 or 60 hertz.

CONTROL: BPAC-3: A 135 ohm to A 5000 ohm potentiometer or 0-5 VDC signal. Other voltage or ma inputs by using a range card.

AUXILIARY CIRCUIT: Interlock terminals 1 and 2.

TERMINALS: Compression Terminals. Up to 800 amps.

DIMENSIONS: See Figure 10.

WIRING: See Figures 1-9.

APPROVAL: Underwriters' Laboratories. Component recognized under U.L. file E 67609 (up to 600 A only)

FUSING: Must be externally fused with 12t, current limiting fuses. (Except BPAC-43)

CONTROL WIRING

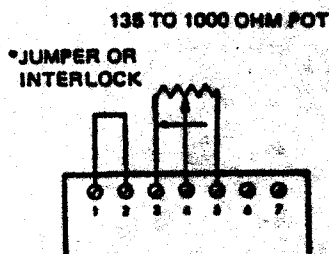

Single Unit-Potentiometer Control.

FIGURE 6

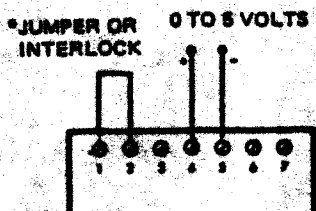

Single Unit-DC Voltage Control.
Impedance is 22K. Full Current
Less than 1/4 Milliampere.

FIGURE 7

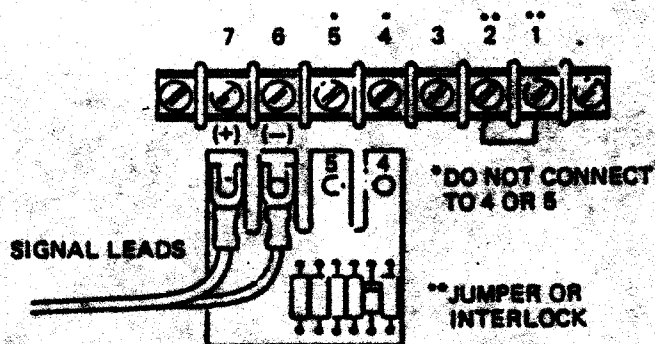

Single unit with range card for ma or special voltage inputs. See
Range Card Instructions.

FIGURE 8

Interlock terminals can be used for control functions only. Do not use for any safety or shut down functions.

On units 300 amp or larger terminals 1+2 are used for heat sink thermostats. Any interlocks must be wired in series with terminal #1.

START UP

1. Temporarily bypass BPAC and run heaters direct. Measure load currents to be sure ampere draw does not exceed rating of BPAC selected.
2. Connect BPAC as shown for proper unit (power wiring) Figure 1-5.
3. Connect control signal per Figure 6-9.
4. Apply power and set temperature control or room thermostat for zero output. No output voltage or current should appear at load.
5. Set temperature control or room thermostat for partial heat. The load voltage or current should read partial output and be cycling on and off at a rapid rate.

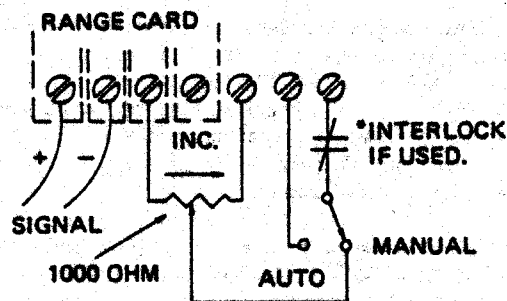

FIGURE 9

AUTO MANUAL OPERATION WITH RANGE CARD.

6. Turn temperature control or room thermostat to give full output. Full output voltage and current should appear at load terminals.
7. ON THREE PHASE UNITS:
Measure the voltage from the T1 to T2, T2 and T3, and T3 to T1. If more than 10% unbalance exists switch any two incoming lines. ("L" side)

POWER WIRING

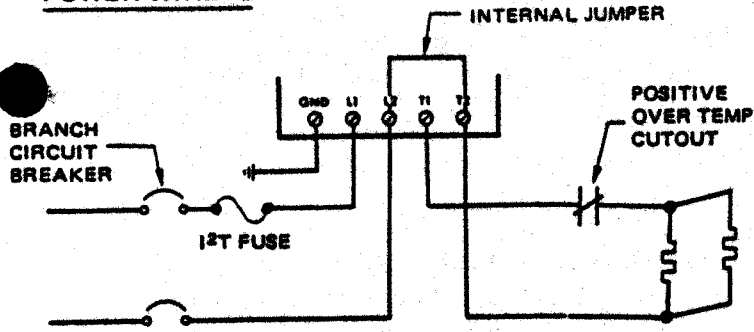

FIGURE 1
Single Phase: 10-100 amps
120, 208, 240, 277, 380, 480, 600 volts.

KVA RATING OF TOTAL LOAD MUST NOT EXCEED KVA RATING OF BPAC 1

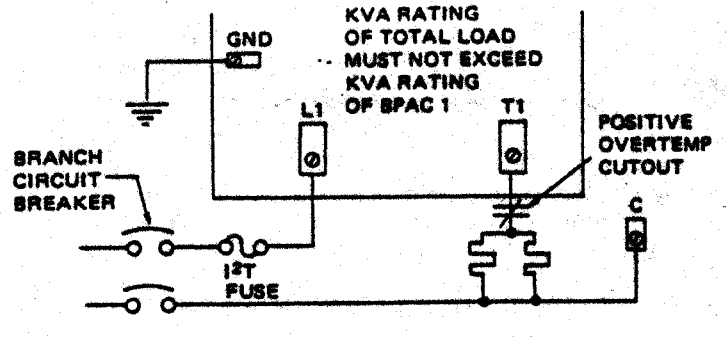

FIGURE 2
Single Phase: 150-600 amps
120, 208, 240, 277, 380, 480, 600 volts.

KVA RATING OF TOTAL LOAD MUST NOT EXCEED KVA RATING OF BPAC 1

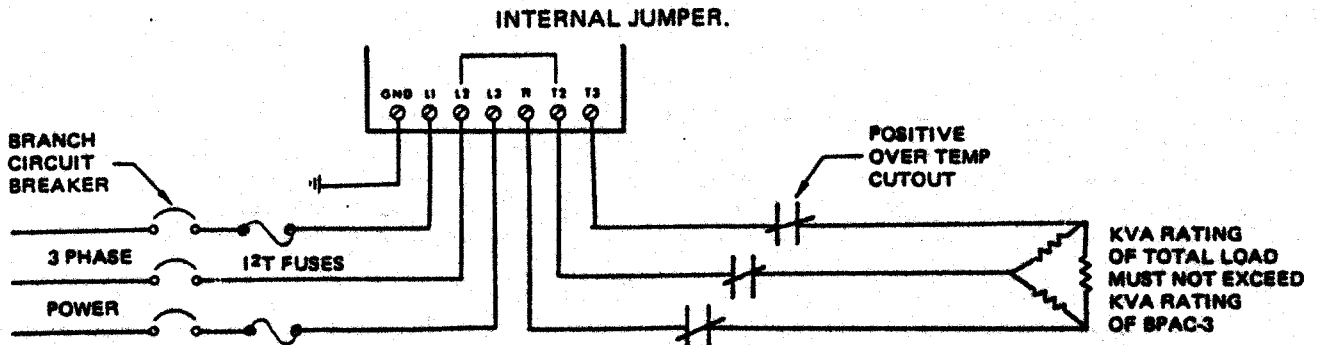

FIGURE 3 Three Phase Three wire 10-200 amps.
208, 240, 380, 480, 600 volts.

KVA RATING OF TOTAL LOAD MUST NOT EXCEED KVA RATING OF BPAC-3

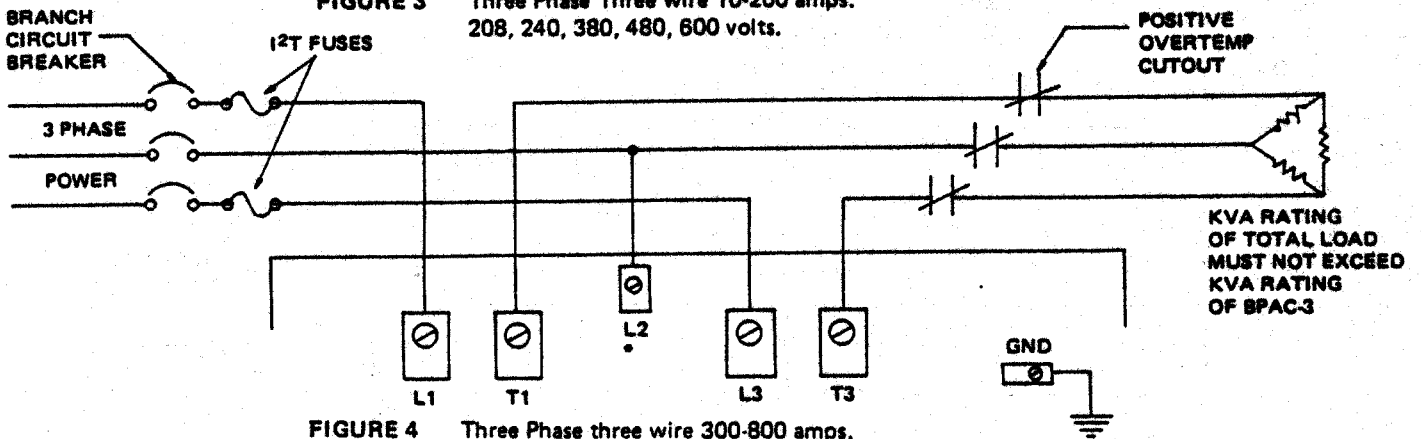

FIGURE 4 Three Phase three wire 300-800 amps.
208, 240, 380, 480 or 600 volts.

*Use 12-14 AWG.

KVA RATING OF TOTAL LOAD MUST NOT EXCEED KVA RATING OF BPAC-3

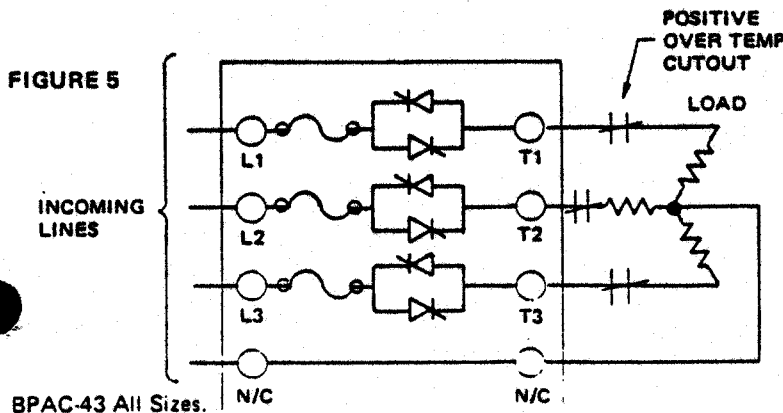

FIGURE 5

KVA RATING OF TOTAL LOAD MUST NOT EXCEED KVA RATING OF BPAC 43

WIRING:

All wiring must comply with applicable codes, regulations, and ordinances. Connect the wires to the appropriate marked terminals. The wires connected to the resistive load and to the power line should be adequate to carry the resistive heater current.

NOTE: Half-wave DC is supplied at terminals 3 (+) and 5 (-). As a result, a volt meter reading will show only 2.5 volts when the half-wave value is 5 volts. Applies to serial numbers 21800 and later.

NOTE: The normal failure mode of an SCR is full output. Do not use interlock for over-temperature or safety interlocks where open circuit protection is required.

LOAD: The BPAC is designed for directly connected, resistive loads.

REPAIR AND SERVICE

Consult Loyola Controls Inc. or your local representative, for your nearest service center.

MAINTENANCE INFORMATION:

The BPAC Troubleshooting Guide, is available upon request. It is intended for qualified technicians only.

DIMENSIONS:

DIMENSIONS SINGLE PHASE				THREE PHASE 3 WIRE			THREE PHASE 4 WIRE		
UNIT SIZE	HIGH	WIDE	DEEP	HIGH	WIDE	DEEP	HIGH	WIDE	DEEP
10, 20, 30, AMP	10.375	5.375	5.75	10.375	10.625	5.75	26.65	19	4
50 AMP	10.375	10.625	5.75	19	12	6.50	26.65	19	4
75-100 AMP	10.375	10.625	7.375	19	12	8	26.25	19	5
150-200 AMP	12.25	19	4.25	24	19	4.25	26.25	19	5
300 AMP	17.25	19	8.25	24	19	8.25	consult factory		
400-600 AMP	33	21	14	33	27	14	consult factory		
800-2000 AMP	33	27	14	45	33	15	NA	NA	NA

FIGURE 10