

Indirect Heat Exchanger Ideal for a Wide Range of Dry Gas Seal Applications



HYDROSAFE®, Watlow's new indirect electric heat exchanger for dry gas seal applications, has been designed as a standardized thermal solution that minimizes custom engineering requirements because it can be adapted to a variety of conditions. The HYDROSAFE provides very flexible heating capabilities (12 to 31.2 kW) to compensate for changes in gas flow rates, or changes in gas composition, when interconnected to our purpose engineered WATCONNECT® control panel. Multiple units may be connected in series for higher kW needs.

The HYDROSAFE holds complete assembly hazardous certifications with a "touch-safe" exterior versus competitors that offer enclosure-only certifications.

The seal gas is heated inside a small diameter seamless formed cylinder to allow for high system pressure capability requirements. In addition to high pressure capabilities, up to 6800 psi (469 bar) in the standard offering, the heater is up to 50 percent smaller than comparable circulation heaters. The empty weight of the HYDROSAFE heater is about 300 pounds (136 kgs) maximum. This small footprint and weight allow the user to reduce the cost of the supporting super structure on rigs, platforms, FPSOs, vessels, etc.

Indirect technology means there is no concern about your seal gas stream ever coming into contact with the heating elements, especially when elements reach end-of-life conditions and are typically more susceptible to corrosion. The small diameter and low volume pressure boundary allow use in many countries without the need for further pressure vessel certifications.

HYDROSAFE is extremely reliable and has been tested in both the Watlow lab and in the field. It also holds all necessary certifications including IECEx, ATEX, ASME and CSA/NRTL. The formed cylinder raw material is listed in accordance with NACE and ISO standards including MR 0175/ISO 15156/MR 0103.



Standard Performance Capabilities

- **Wattages:** from 12 to 31.2kW
- **Voltages:** from 380 to 600VAC
- **Design temperature:** -50 to +300°C (-58 to 572°F)
- **Design pressure:** up to 6800 psi (469 bar)*
- **Inlet temperature:** user specified
- **Outlet temperature:** maximum 232°C (450°F)**
- **Working pressure:** user specified
- **Flow rate:** user specified
- **Maximum back pressure:** user specified
- **Maximum ambient temperature:** 50°C (122°F) for North American certifications, 80°C (176°F) for IEC and ATEX certifications
- **Media phase:** liquid or gas
- **Typical Media:** methane, natural gas (methane, butane, propane, ethane and water vapor) and nitrogen
- **Environment T code rating:** none, T2, T3 and T4

Features and Benefits

Fluid path constructed independent from the sheath

- Allows sensitive materials to be heated safely and effectively
- Assures safety because heater failure will not cause leaks or significant damage
- Prevents fluid contamination

Seamless fluid path construction

- Offers economical package price
- Minimizes potential leakage
- Allows high-pressure operation

Standard 316L SS fluid path

- Provides compatibility with different materials
- Assures high-pressure application reliability

* Higher custom pressures available

** T Code dependent

HYDROSAFE Heater Assembly Specifications

HYDROSAFE Assembly	Standard Offering	Standard Options	Other Available Options
Base Construction	Fully certified indirect electric heat exchanger assembly - flow coil and tubular elements cast into an aluminum cylinder. Complete with sensors, enclosure, insulation, nozzles and shroud.		
Control Configuration	Cascade using one internal cascade sensor per heater assembly (included) and separate process temperature sensor (not included)		
Casting Material	Al Alloy 356		
Corrosion Protection on Casting	Corrosion and weather protectant high temperature coating to 538°C (1000°F)		
Number of Flow Coils	1		
Heater Element	Tubular elements - 0.430 in. O.D. x 0.035 in. wall, 316 stainless steel, NiCr resistance element, welded wire connection, bright annealed		
Heater Element Moisture Seal	Epoxy 180°C (356°F) rated		
Casting Insulation	Aerogel insulation		
Baseplate, Top Plate, Stand-off Shroud, Casting Shroud Material	316 stainless steel		
HYDROSAFE Assembly Area Classification - Certification	North American (Class 1, Div. 1 & 2, Groups B, C, D)	ATEX (Ex d IIC) and/or IEC (Ex d IIC)	—
HYDROSAFE Assembly T Code Rating	None, T2 or T3	—	—
Maximum Casting Temperature Limit	150°C (302°F) for T3, 250°C (482°F), for T2	—	—
Pressure Boundary Compliance	Design, calculation and production acc. to ASME VIII Div. 1	—	Contact Watlow
Electrical			
Voltage	480V or 400V	380, 415, 440, 460, 575, or 600	—
Voltage Supply	3 Phase AC + ground, with or without neutral connection (assembly is universally configured for both)		
Frequency	50 or 60 Hz		
Wattage (at specified voltage)	31.2kW (480V and 600V) or 28.9kW (400V)	26.07kW (380V), 31.1kW (415V), 28.65kW (460V and 575V), 26.22kW (440V)	10.4kW (480V), 7.22kW (400V), 6.52kW (380V)
Number of Heater Supply Circuits	1		
Max Amperage per Circuit	Voltage/wattage dependent (max. 45 amps in any configuration)		
Power Connection Entry Size	1 in. NPT coupling or 1 in NPT x M32 x 1.5 (See Item 9, Ordering Information on page 4)		
Power Connection within Enclosure	Compression type, screw style distribution terminal block on DIN-rail within enclosure (3-phase + neutral) Compression type, screw style ground terminal block in enclosure (ground) Split bolt ground termination on external enclosure (with ATEX or IEC option)		
Flow Coil			
Vessel Coil Material	316/316L (dual rated)	—	Inconel® 625, Super Duplex 2507
Vessel Coil Raw Material Certifications	NACE MR-0175 / ISO15156 and MR-0103 with applicable technical circulars and addendas		
Inlet/Outlet			
Inlet/Outlet Connection Type	Standard flange	—	High pressure hub type connector
Inlet/Outlet Connection Material (match flow coil)	316/316L (dual rated)	—	Inconel® 625, Super Duplex 2507
Inlet/Outlet Connection	ANSI 1 in., Class 600, RF, sched 80 bore	ANSI 1 in., Class 2500, RTJ, sched 160 bore	Clamp hub
Inlet/Outlet Nozzle Connection Gaskets	—	Spiral wound or ring joint	—
Enclosure			
Enclosure Type	304 stainless steel (North America) painted carbon steel (IEC/ATEX)	316 stainless steel (North America) or (IEC/ATEX)	—
Enclosure Paint Color (only if Painted Carbon Steel)	RAL 7035 light grey	—	Other - custom color to be reviewed by factory (painted carbon steel enclosure only)
Enclosure Rating	See Item 7, Ordering Information on page 4		
Enclosure Anti Condensation Heater	None	—	Enclosure heater
Hazardous/Non-Hazardous Area Classification	Per assembly hazardous location rating		
External Enclosure Hardware	316 stainless steel		

HYDROSAFE Heater Assembly Specifications (con't)

HYDROSAFE Assembly	Standard Offering	Standard Options	Other Available Options
Sensors			
Process and Limit Temperature Sensor Type	Duplex Pt 100, 3 wire RTDs 300 series stainless steel sheath	—	Duplex thermocouple - Type K 300 series stainless steel sheath
Number of Sensors	3		
Sensor Junctions	(1) Cascade process sensor, (1) Spare (1) Internal casting high limit, (1) Spare (1) Enclosure high limit, (1) Spare		
Inlet or Outlet Sensors	Customer supplied (not included)		
Sensor Connection Entry Size	See Item 9, Ordering Information on page 4		
Sensor Connections within Control Panel	3 wire RTD terminal blocks within heater enclosure	—	Type K thermocouple terminal blocks within heater enclosure (when thermocouple option selected)
Testing			
Pressure Testing (Hydro)	Standard on all assemblies per pressure vessel code requirements (15 minutes @ 1.3 x MAWP x LSR)	—	Custom time for hydro test
Other Options			
Country of Origin Materials	Watlow standard vendors - no restrictions	—	Certified countries

HYDROSAFE Specifications

Design temperature

- 50 to +300°C (-58 to 572°F)

Design pressure

- Up to 6800 psi (469 bar)

Weight (empty) maximum

- 300 lbs (136kg)

Inlet temperature

- User specified

Outlet temperature

- Max. 232°C (450°F)

Working pressure

- User specified

Flow rate

- User specified

Maximum back pressure

- User specified

Maximum ambient temperature

- 50°C (122°F) for North American certifications, 80°C (176°F) for IEC and ATEX certifications

Media type

- Liquid or gas

Media

- Methane, natural gas (methane, butane, propane, ethane and water vapor) and nitrogen

Environment T code rating

- None, T2, T3 or T4

Dimensional Drawings

Front View

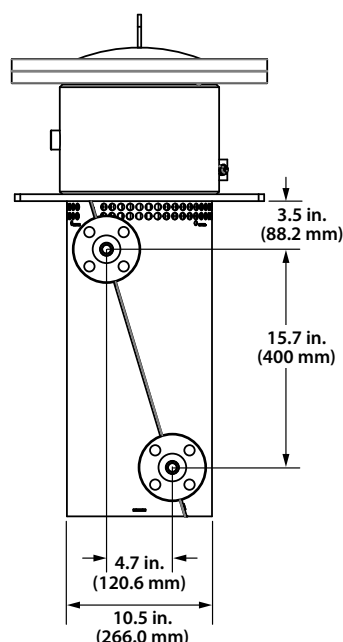

Side View

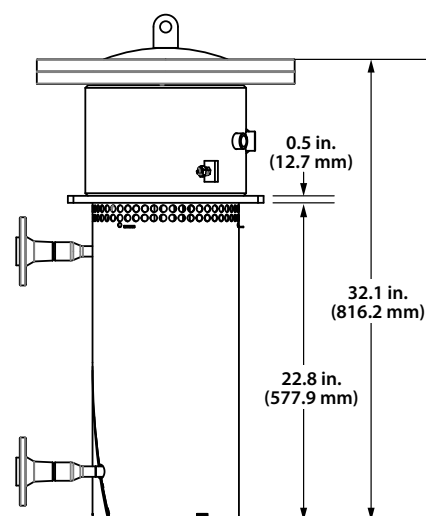

Top View

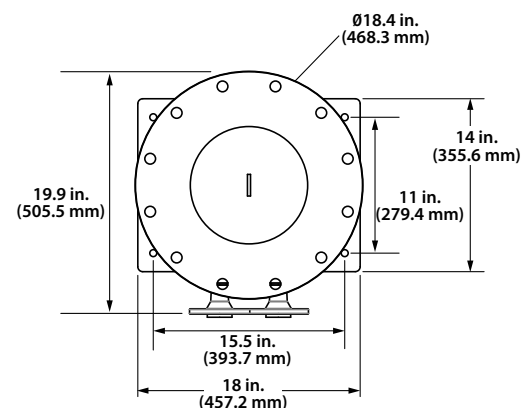

Note: Dimensions shown are approximate. Configuration GA drawing available with order or quote.

HYDROSAFE Ordering Information

Part Number

①	②	③	④	⑤	⑥	⑦	⑧	⑨	⑩	⑪	⑫	⑬ ⑭ ⑮
	Gen. Size & Power	Input Voltage/Phase	In/Out & Gasket	Connect & Coil Material	Temperature Sensors	Assembly Cert. & Encl. Matl.	Design & Fab.	Power & Sensor Connections	Elec. Encl. Htr.	Testing Options	Material C.O.O.	Custom Options
H												AAA

② General Size & Power	
S =	Future option
M =	Medium (12 to 31.2kW)
L =	Future option

③ Input Voltage/Phase	
A =	Future option
B =	Future option
C =	Future option
D =	Future option
E =	Future option
F =	26.07kW, 380V (medium size only)
G =	28.65kW, 460V or 575V (medium size only)
H =	28.9kW, 400V (medium size only)
J =	31.1kW, 415V (medium size only)
K =	31.2kW, 480V or 600V (medium size only)

④ Inlet & Outlet Connection & Gasket Selection	
A =	Future option
B =	Future option
C =	Clamp hub 1 in. NPS 4 bolt without gasket
D =	ANSI 1 in. CI 600 RF, sched 80 bore without gasket
E =	Future option
F =	Future option
G =	ANSI 1 in. 2500 RTJ, sched 160 bore without gasket
H =	Clamp hub 1 in. NPS 4 bolt with gasket
J =	ANSI 1 in. CI 600 RF, sched 80 bore with spiral wound gasket
K =	ANSI 1 in. 2500 RTJ, sched 160 bore with ring joint gasket

⑤ Connection & Flow Coil Material	
A =	316/L stainless steel
B =	Inconel® 625 or equivalent
C =	Duplex stainless 2507

⑥ Temperature Sensors	
1 =	RTD 3 wire 100 ohm
2 =	Thermocouple Type K

⑦ Assembly Certification & Enclosure Material	
1 =	CI 1, Div. 1 & 2, Groups B, C & D; 304 stainless steel, Type 4X
2 =	CI 1, Div. 1 & 2, Groups B, C & D; 316 stainless steel, Type 4X
3 =	IEC & ATEX Dual Rated Ex d IIC; painted carbon steel, IP66
4 =	IEC & ATEX Dual Rated Ex d IIC; 316 stainless steel, IP66
5 =	Future option

⑧ Design and Fabrication	
A =	Design/Calculations in accordance to ASME VIII Div. 1
B =	Design/Calculation/Fabrication in accordance to ASME VIII Div. 1
C =	Design/Calculations in accordance to PED
D =	Design/Calculation/Fabrication in accordance to PED
E =	CRN (per ASME VIII Div. 1) + B

⑨ Power & Sensor Connection Entries (female couplings)	
1 =	(1) 1 in. NPT coupling for power, (3) 3/4 in. NPT couplings for sensors
2 =	(1) M32 x 1.5 coupling for power, (3) M25 x 1.5 couplings for sensors
3 =	(1) 1 in. NPT coupling for power, (3) 1/2 in. NPT couplings for sensors
4 =	(1) M32 x 1.5 coupling for power, (3) M20 x 1.5 couplings for sensors

⑩ Electrical Enclosure Heater	
1 =	Yes, 220V
2 =	No

⑪ Testing Options	
A =	Watlow standard tests
B =	Custom time length hydrostatic pressure (includes option A)
C =	Radiography of heating coil weld joints (includes option A)
D =	Dye penetrant of heating coil weld joints (includes option A)
E =	PMI of pressure boundary materials (includes option A)
F =	A + B + C + E
G =	A + B + D + E

⑫ Material Country of Origin	
1 =	Watlow standard
2 =	Watlow standard with no China origin
3 =	Watlow standard with no India Origin
4 =	Watlow standard with no Indonesia Origin
5 =	Watlow standard with no Russia Origin

⑬ ⑭ ⑮ Custom Options	
AAA =	Standard

Watlow®, WATCONNECT® and HYDROSAFE® are registered trademarks of Watlow Electric Manufacturing Company.

Inconel® is a registered trademark of Special Metals Corporation (formerly Inco).

Powered by Possibility



To be automatically connected to the nearest North American Technical Sales Office:
1-800-WATLOW2 • www.watlow.com
inquiry@watlow.com

International Technical Sales Offices:

Austria	+43 6244 20129 0	India	+91 40 6661 2700
China	+86 21 3532 8532	Italy	+39 02 458 8841
France	+33 1 41 32 79 70	Japan	+81 3 3518 6630
Germany	+49 7253 9400 0	Korea	+82 2 2169 2600

Mexico	+52 442 256 2200
Singapore	+65 6773 9488
Spain	+34 91 675 1292
Taiwan	+886 7 288 5168
UK	+44 115 964 0777