

Specialty Heaters



Specialty Heaters	Sheath Materials	Max. Operating Temperatures		Typical Max. Watt Densities		Page
		°F	°C	W/in ²	W/cm ²	
FLUENT® In-line	444 stainless steel (substrate tube), 316L stainless steel (baffle and fittings)	482	250	450	70	443
ULTRAMIC® Advanced Ceramic	Aluminum nitride	1112	600	1000	155	447
Coil/Cable	304 stainless steel or alloy 600	1200	650	30	4.6	451



Specialty Heaters



FLUENT® In-line Heaters

Watlow's FLUENT® in-line fluid heater is a small, lightweight, high-performance heater that can replace both a traditional immersion type heater or a heater wrapped around a tube as part of a thermal system. Watlow's FLUENT heater is designed as an integrated solution that replaces multiple components in a system. This heater design reduces overall system cost and complexity. Because of its high watt density, it offers ultra-fast response leading to higher system performance. Featuring Watlow's patented layered heater technology, the heater makes use of its entire surface to produce heat, which optimizes heat transfer and temperature uniformity.

Features and Benefits

Small, lightweight, robust heater construction

- Replaces multiple components in a system
- Reduces overall system size
- Lowers total cost of ownership

Patented circuit patterning process

- Facilitates customizable heating profiles
- Enables distributed wattage and/or multiple zones
- Assures precise and repeatable power distribution

High watt density, low mass heater

- Contributes to fast response time
- Allows for efficient heat transfer
- Enables on-demand process start-up



Typical Applications

- Hemodialysis fluid heating
- Food cooking equipment
- Semiconductor purge and carrier gas heating
- Ink preheating systems
- On-demand fluid heating

Specialty Heaters



FLUENT In-line Heaters

Technical Information

Specifications

- Substrate tube material: 444 SS
- Fitting and baffle material: 316L SS
- Voltage up to 240V
- Amperage up to 15A per zone
- Resistance tolerance +10%, -5%
- Typical maximum watt densities
 - Air 150 W/in² (23 W/cm²)
 - Water 450 W/in² (70 W/cm²)
- Maximum pressure: 150psi (10.2 bar)
- Maximum temperature: 662°F (350°C) as measured by internal T/C
- UL®/cUL® and CE

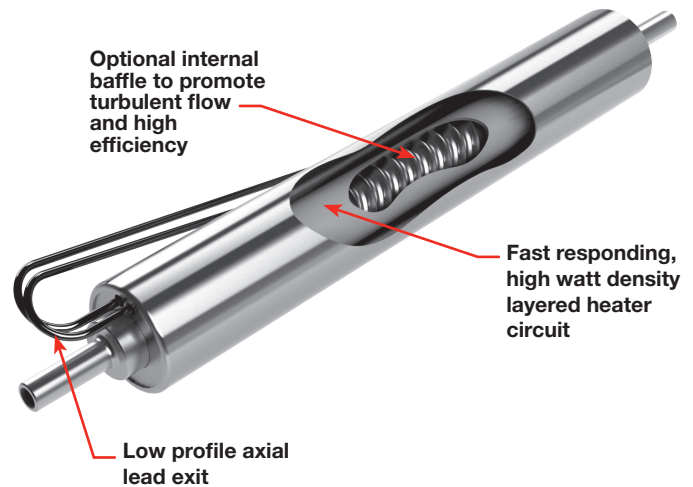

Application Orientation

Gas Heating—
(Any orientation)



Liquid Heating—
(Heater must be vertical with inlet at the bottom)



Inlet/Outlet Fitting Options

1 Inch Outer Diameter Heaters

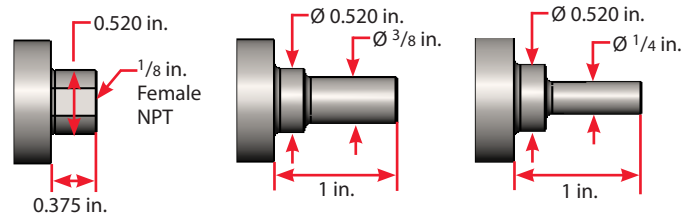

1 5/8 Inch Outer Diameter Heaters

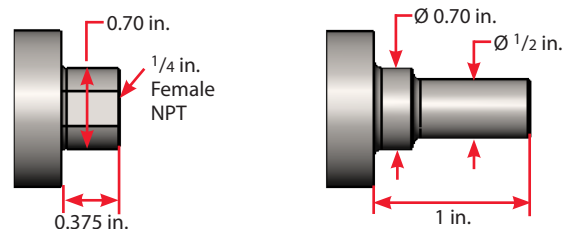

Standard Construction

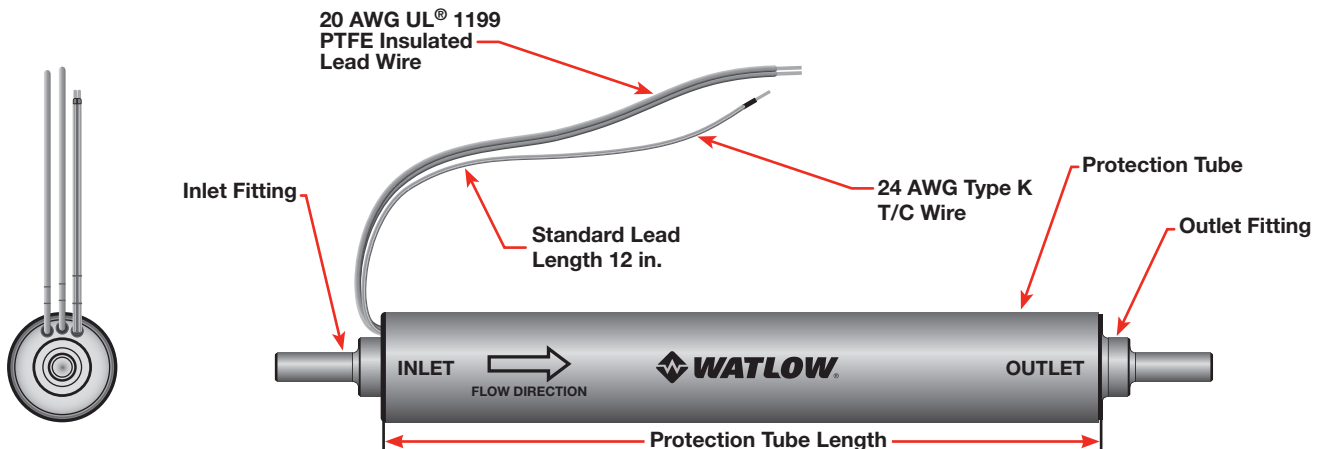



FLUENT In-line Heaters

Technical Information

Standard Product Offering: Base Heaters

Volts	Watts	Number of Heating Circuits	Outer Diameter in. (mm)	Protection Tube Length in. (mm)	Watt Density (W/in ²)
240	500	1	1 (25)	3.00 (76)	210
120	250	1	1 (25)	4.25 (108)	57
240	1000	1	1 (25)	4.25 (108)	228
120	375	1	1 (25)	5.25 (133)	62
240	1500	1	1 (25)	5.25 (133)	247
120	500	1	1 (25)	6.50 (165)	63
240	2000	1	1 (25)	6.50 (165)	250
120	750	2	1 (25)	6.50 (165)	94
240	3000	2	1 (25)	6.50 (165)	375
120	1000	2	1 (25)	7.75 (197)	100
240	4000	2	1 (25)	7.75 (197)	400
240	500	1	1 (25)	6.50 (165)	63
120/240	1000/4000	1	1 ⁵ / ₈ (41)	6.50 (165)	75/300
120/240	1500/6000	2	1 ⁵ / ₈ (41)	10.00 (254)	61/245
120/240	2000/8000	2	1 ⁵ / ₈ (41)	12.00 (304.8)	61/245

How to Specify a Standard Product:

- Select a base heater from the chart to the left.
- Choose the desired inlet and outlet fittings from page 446.

Note: Visit www.watlow.com/fluent for the latest list of standard designs and product information.

Pressure Drop - Air - With Internal Baffle @ 250°C

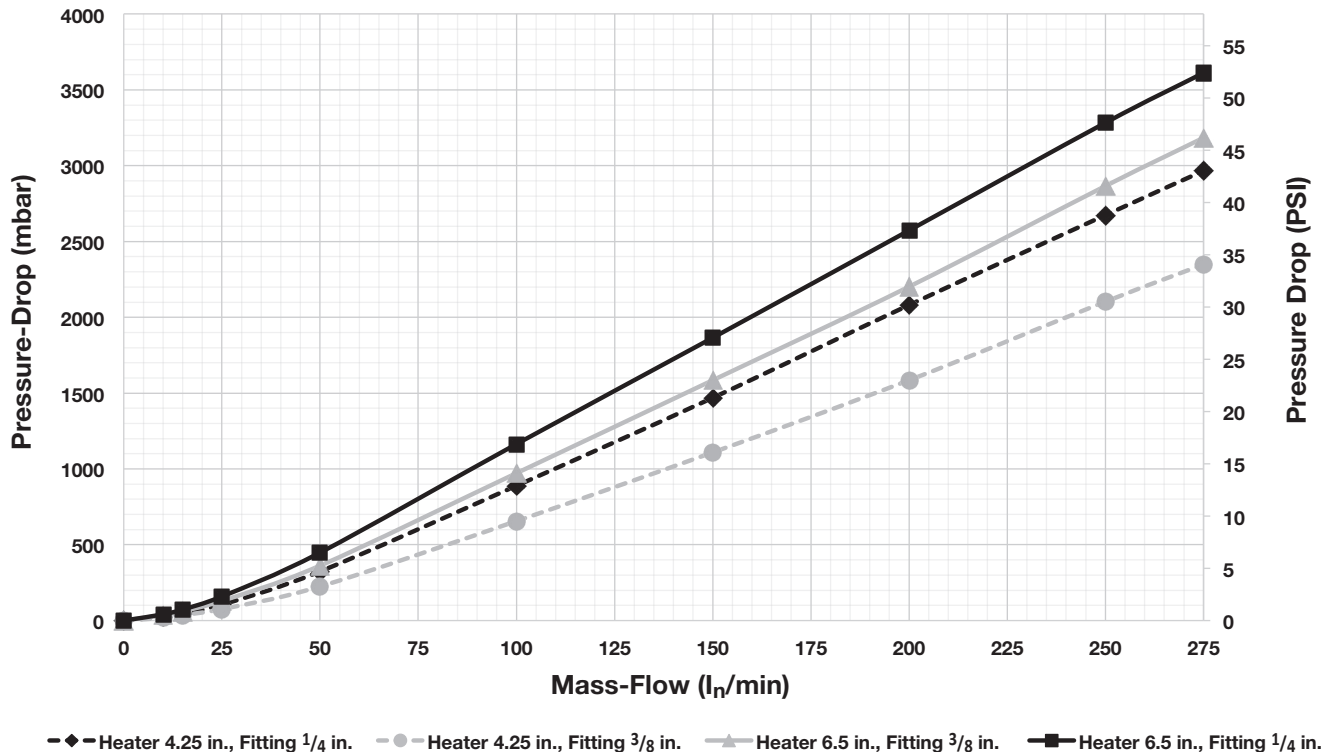

Note: Internal baffle is required for all gas heating applications.



FLUENT In-line Heaters

Technical Information

Pressure Drop - Water - With Internal Baffle

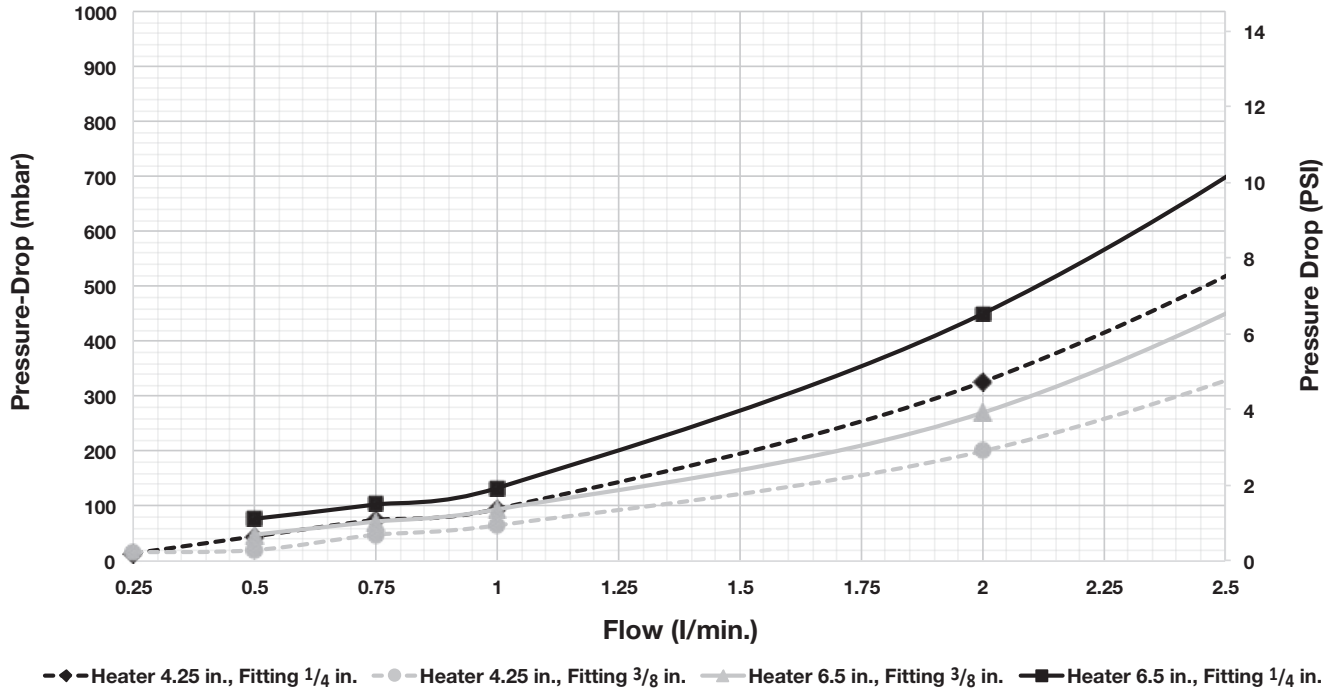

Pressure Drop - Water - Without Internal Baffle

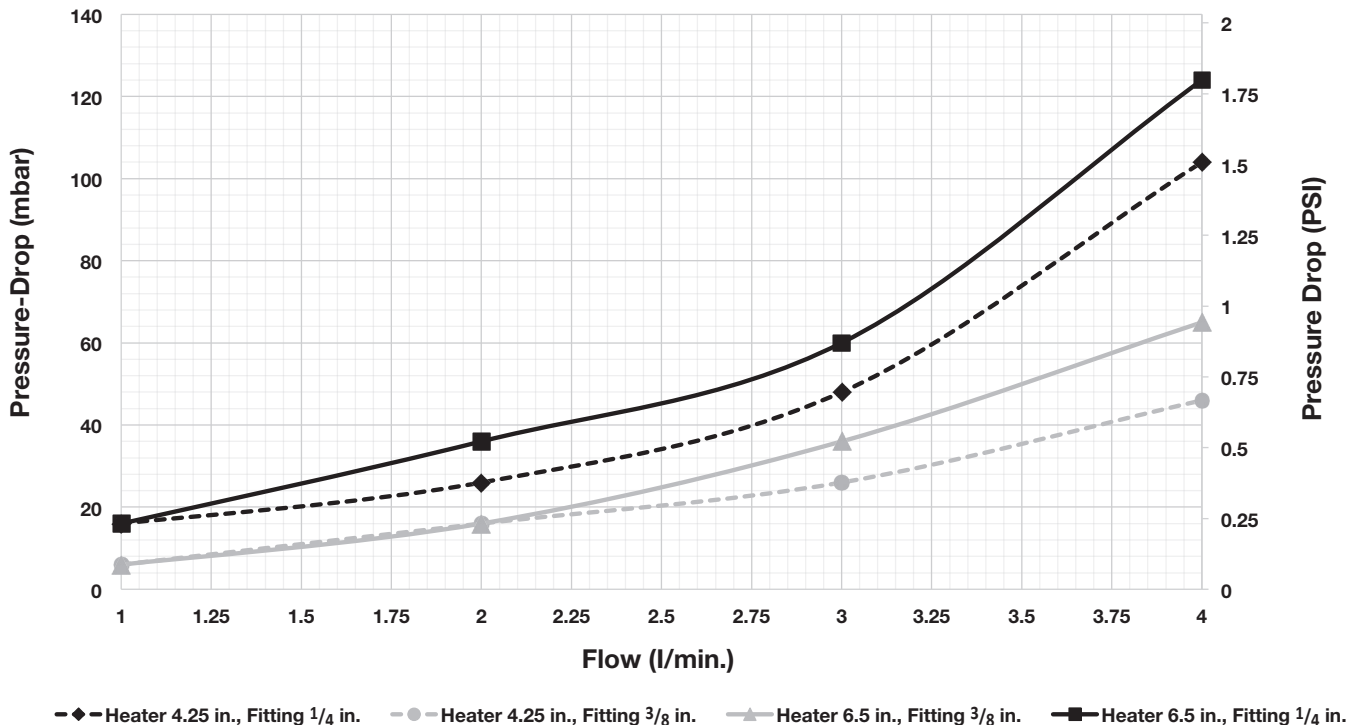

Heater internal temperature will vary based on flow rate, heater watt density and presence of the internal baffle, which increases turbulent flow. General guidelines for baffle consideration:

- For flow rates below 1 l/min, baffle should always be used to prevent an over-temperature condition.
- For flow rates over 1 l/min, removing the baffle is possible but will result in a higher internal temperature.

Specialty Heaters



FLUENT In-Line Heaters

Technical Information

1.625" OD - Pressure Drop - Air - With Internal Baffle @ 225°C

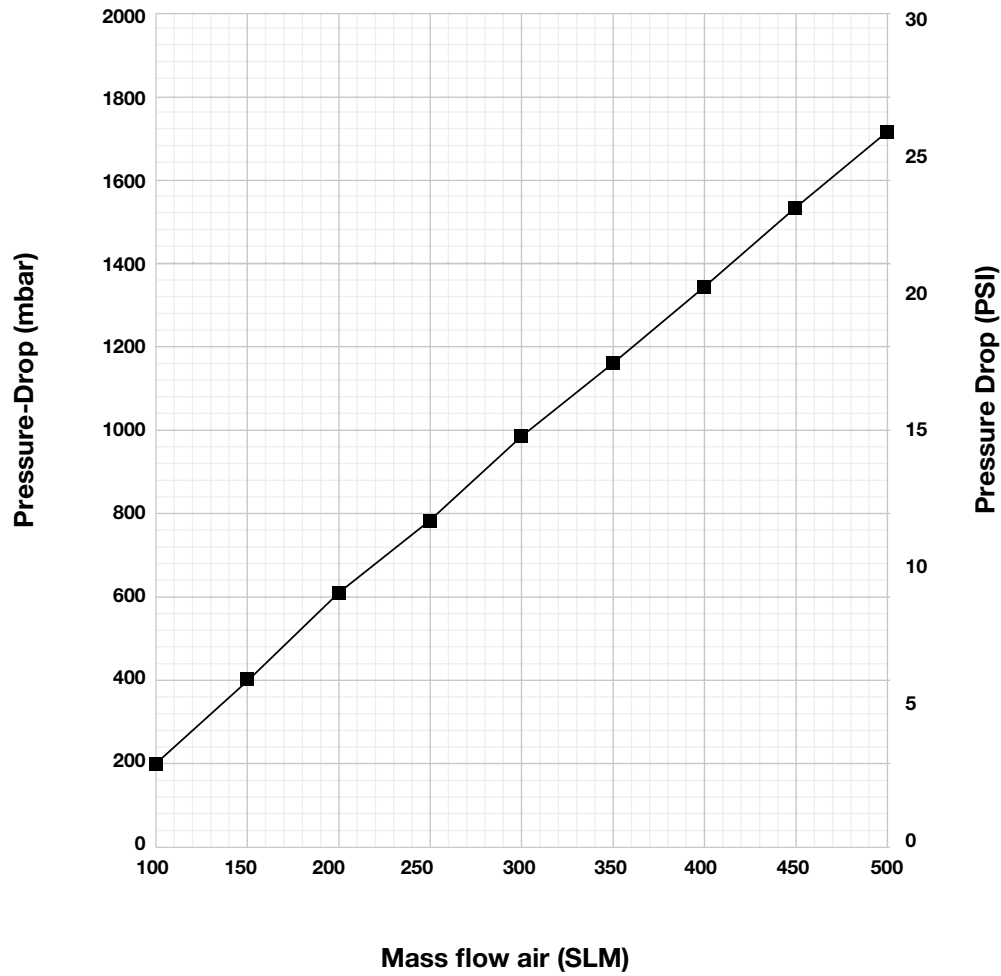

Specialty Heaters



ULTRAMIC® Advanced Ceramic Heaters

Watlow's high performance ULTRAMIC® advanced ceramic heaters are designed for thermal applications that require optimal effectiveness of equipment and processes.

Constructed with aluminum nitride (AlN), ULTRAMIC heaters' thermally matched proprietary heating element provides maximum performance in challenging applications. AlN is especially suitable for applications that require a clean, non-contaminating heat source. Its excellent geometric stability ensures consistent part-to-part thermal contact during heating cycles.

Watlow AlN heaters operate up to 400°C (752°F)^① with an ultra-fast ramp rate of up to 150°C (270°F) per second depending on the application, heater design and process parameters. In addition to its excellent thermal characteristics, the ULTRAMIC provides high electrical isolation and typically provides superior chemical resistance compared to traditional metal heaters.

Performance Capabilities

- Standard operating temperature up to 400°C (752°F)^①
- Watt densities up to 155 W/cm² (1000 W/in²)
- Temperature ramp rate up to 150°C (270°F) per second (depending on application parameters)

Features and Benefits

Robust AlN ceramic

- Creates a homogeneous assembly for atmospheric and vacuum applications
- Provides durable heater construction and thermal transfer necessary for high temperature and long heater life
- Supports the design of a high watt density, fast responding heater in a very small package
- Ensures geometric stability due to low coefficient of thermal expansion

Superior electrical performance

- Assures low leakage current
- Enables high breakdown voltage

^① 400°C (752°F) maximum operating temperature is standard. Higher temperature operation up to 600°C (1112°F) is available as an extended capability. Contact your Watlow representative for information.

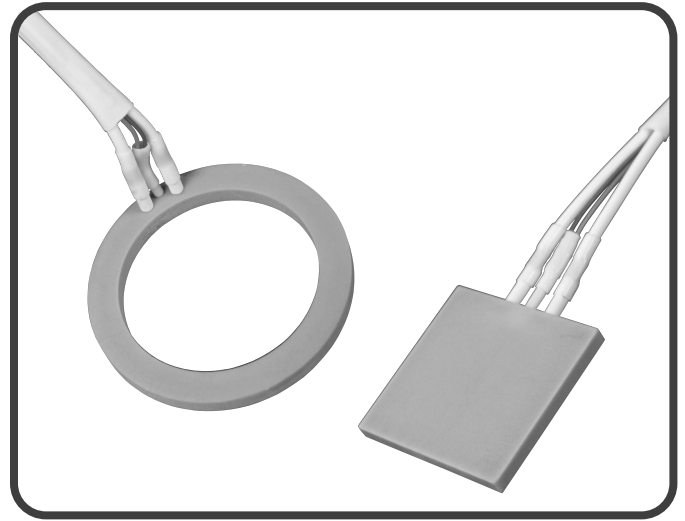

High thermal conductivity

- Makes for an ultra-fast temperature ramp rate of up to 150°C (270°F) per second (depending on application parameters)
- Allows for quick cool-down
- Provides extremely uniform temperatures over the heater's surface

Type K thermocouple or 100 Ohm RTD integrated into assembly

- Ensures reliable heater/sensor interface
- Improves accuracy with optimized temperature sensing
- Provides ramping applications with a high response rate

UL® and CE agency compliance

- Meets global safety standards
- Includes RoHS compliance

Typical Applications

- Wire and die bonding
- Integrated circuit (IC) chip testing
- Mass spectrometry
- Clinical diagnostic equipment
- High speed packaging/sealing
- Respiratory therapy equipment



ULTRAMIC Advanced Ceramic Heaters

Technical Data

Mounting Guidelines

- Temperature <math><200^{\circ}\text{C}</math> (392°F): bond with high-temperature epoxy adhesive
- Clamp using single or multiple-point fasteners

Integrated Temperature Sensors

- Bonded Type K thermocouple
- 100 Ohm RTD

Specifications and Tolerances

Surface Finish

- Flatness: <math><0.05\text{ mm}</math> (0.002 in.)
- Parallelism: <math><0.05\text{ mm}</math> (0.002 in.)
- Surface roughness (Ra): <math><1.5\text{ }\mu\text{m}</math>

Dimensional Tolerance (length/width/diameter)

- $\pm 1\%$ of dimension ($\pm 0.13\text{ mm}$ minimum)

Electrical Properties

- TCR: $0.0015/^{\circ}\text{C}$
- Resistance tolerance: $\pm 25\%$

Intellectual Property

- U.S. Patents 7,696,455, 7,832,616 and 8,242,416

Lead Wire and Terminations

- Power terminals exit locations — extended from side edge or top face
- PTFE insulated silver-plated copper lead extension
- Lead extension length — standard length 305 mm (12 in.)
- Optional length of ceramic beads

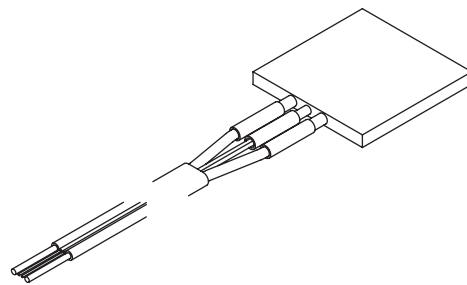

Side Lead Exit

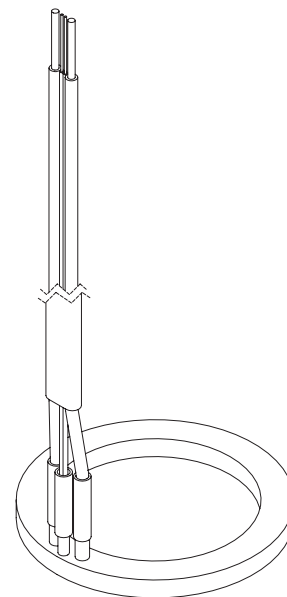

Top Lead Exit

Specialty Heaters

**EXTENDED
CAPABILITY**



Extended Capabilities for ULTRAMIC Advanced Ceramic Heaters

Mounting Guidelines^①

- In addition to the options listed on the previous page, a screw hole can be provided on custom designs (recommend insulation buffer such as mica spacer)

Optional Sensors

- In addition to, or in place of the standard thermocouple or RTD, a drilled hole or slot can be provided for installing an externally mounted sensor

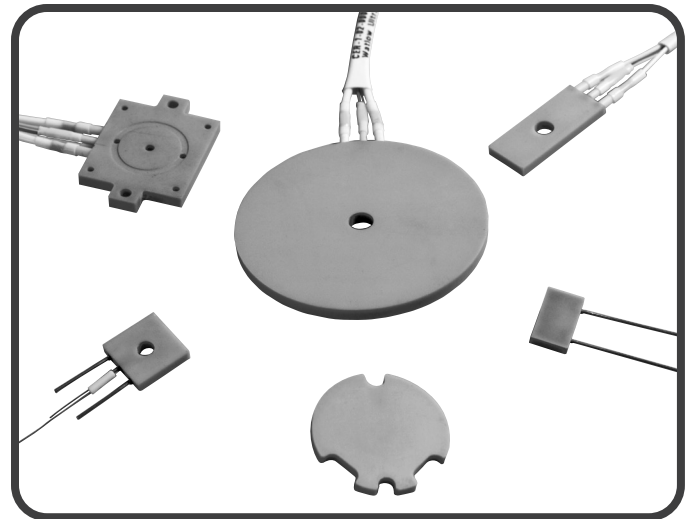

Configurations and Dimensions

Dimensional Features				
	Length	Width	Thickness	Aspect Ratio
Flat Square	Min: 8 mm (0.315 in.) Max: 100 mm (3.94 in.)		Min: 2.5 mm (0.098 in.) Max: 5 mm (0.196 in.)	1
Rectangular	Max: 100 mm (3.94 in.)	Min: 8 mm (0.315 in.)	Min: 2.5 mm (0.098 in.) Max: 5 mm (0.196 in.)	<10
	Inside Diameter I.D.	Outside Diameter O.D.	Thickness	Ring Wall Thickness
Ring	Min: 0	Max: O.D. 100 mm (3.94 in.)	Min: 2.5 mm (0.098 in.) Max: 5 mm (0.196 in.)	Min wall thickness: 3 mm (0.118 in.)
Machined Features				
Straight Groove Custom Feature			Hole Size Round Diameter	
Width: 0.5 mm (0.019 in.)			Min: 0.5 mm (0.019 in.)	
Electrical Properties				
Voltage			Max. Temperature	
12 to 480V			400°C (752°F) standard, 600°C (1112°F) extended capability	

^① See www.watlow.com/ultramic for detailed mounting guide.



ULTRAMIC Advanced Ceramic Heaters

Technical Data

Product Ordering Information

Part Number	Dimensions mm (in.)	Thickness mm (in.)	Watt Density	Watts	Volts	Lead Exit
Square						
CER-1-01-00002	25 mm x 25 mm (0.98 in. x 0.98 in.)	2.5 mm (0.10 in.)	High	900	240	Side
CER-1-01-00374	50 mm x 50 mm (1.97 in. x 1.97 in.)	3.0 mm (0.12 in.)	Medium	1938	240	Side
CER-1-01-00093	25 mm x 25 mm (0.98 in. x 0.98 in.)	2.5 mm (0.10 in.)	Low	150	120	Side
CER-1-01-00097	19 mm x 19 mm (0.75 in. x 0.75 in.)	2.5 mm (0.10 in.)	Low	200	120	Side
CER-1-01-00333	15 mm x 15 mm (0.59 in. x 0.59 in.)	2.5 mm (0.10 in.)	Medium	150	48	Side
CER-1-01-00334	12 mm x 12 mm (0.47 in. x 0.47 in.)	2.5 mm (0.10 in.)	High	200	48	Side
CER-1-01-00335	8 mm x 8 mm (0.31 in. x 0.31 in.)	3.0 mm (0.12 in.)	Low	21.6	12	Top
Heaters With Holes						
CER-1-01-00540	12 mm x 12 mm ^① (0.47 in. x 0.47 in.)	2.5 mm (0.10 in.)	Medium	100	24	Side
CER-1-01-00541	25 mm x 25 mm ^② (0.98 in. x 0.98 in.)	2.5 mm (0.10 in.)	High	800	120	Side
CER-1-01-00542	50 mm x 50 mm ^② (1.97 in. x 1.97 in.)	3.0 mm (0.12 in.)	Medium	1500	240	Side
Rectangular						
CER-1-01-00001	25 mm x 15 mm (0.98 in. x 0.6 in.)	2.5 mm (0.10 in.)	High	580	120	Side
CER-1-01-00003	50 mm x 10 mm (1.97 in. x 0.39 in.)	2.5 mm (0.10 in.)	Medium	582	120	Side
CER-1-01-00004	50 mm x 10 mm (1.97 in. x 0.39 in.)	2.5 mm (0.10 in.)	High	775	240	Side
CER-1-01-00005	50 mm x 25 mm (1.97 in. x 0.98 in.)	2.5 mm (0.10 in.)	Medium	1453	240	Side
CER-1-01-00007	75 mm x 25 mm (2.95 in. x 0.98 in.)	2.5 mm (0.10 in.)	Medium	1455	240	Side
CER-1-01-00098	25 mm x 15 mm (0.98 in. x 0.6 in.)	2.5 mm (0.10 in.)	Low	180	120	Side
CER-1-01-00105	50 mm x 25 mm (1.97 in. x 0.98 in.)	2.5 mm (0.10 in.)	Low	100	120	Side
Ring						
CER-1-02-00001	38 mm x 29 mm (1.50 in. x 1.14 in.)	3.0 mm (0.12 in.)	High	733	120	Top
CER-1-02-00002	77.5 mm x 59 mm (3.05 in. x 2.32 in.)	3.0 mm (0.12 in.)	Medium	770	240	Top
CER-1-02-00074	25.4 mm solid disk (1 in.)	2.5 mm (0.10 in.)	Medium	300	120	Side

^① 3 mm (0.12 in.) hole in center of heater

^② 5 mm (0.19 in.) hole in center of heater

See page 450 for lead exit details (full drawings and current list of standard designs available at www.watlow.com/ultramic)

Note: For the most up-to-date options for ULTRAMIC heaters, please use the VISUAL DESIGNER™ tool or e-Solutions configurator.

Configurations include:

- Power lead wires with 305 mm (12 in.) of PTFE insulation
- Bonded Type K thermocouple with 305 mm (12 in.) PTFE insulated lead wires

Note: Maximum temperature is 400°C (752°F). Lead wires are rated to 205°C (401°F).

If ceramic beads are required, please contact your Watlow representative for a quote.

Specialty Heaters



Coil/Cable Heaters

The versatile Watlow coil/cable heater can be formed into a variety of shapes. Small diameter, high performing cable heaters are fully annealed and readily bent to a multitude of configurations.

The heater can be formed into a compact, coiled nozzle heater supplying a full 360 degrees of heat with optional distributed wattage. A straight cable heater can snake through an equipment application. Flat, spiral configurations can be used in high-tech manufacturing while a star wound cable can be used for air and gas heating.

Different applications require different construction methods, including one, two or four resistance wires; parallel coil or straight wire; drawn or swaged sheaths; with or without internal thermocouples; leads exiting from one or both ends, and round, rectangular or square cable cross sectionals.

Whatever the application requirement, a Watlow coil/cable heater can be shaped to fit.

Performance Capabilities

- Continuous operating temperatures up to 1200°F (650°C) with intermittent operating periods achieving up to 1500°F (815°C) dependent on the type of element wire used
- Sheath watt densities on the cable up to 30 W/in² (4.65 W/cm²), and as high as 75 W/in² (11.62 W/cm²) subject to factory approval
- Maximum voltage up to 240V

Features and Benefits

High ductility

- Allows the heater to be cold-formed into almost any shape

Low mass

- Allows quick response in both heating and cooling

Constructed with no open seams

- Enables operation in unusual environments, including cryogenic and sub-freezing temperatures, high vacuum, gaseous and liquid immersion heaters
- Decreases opportunity for corrosion

Constructed of standard 304 stainless steel, optional 316 stainless steel or Alloy 600

- Provides high temperature corrosion and oxidation resistance along with ideal expansion properties

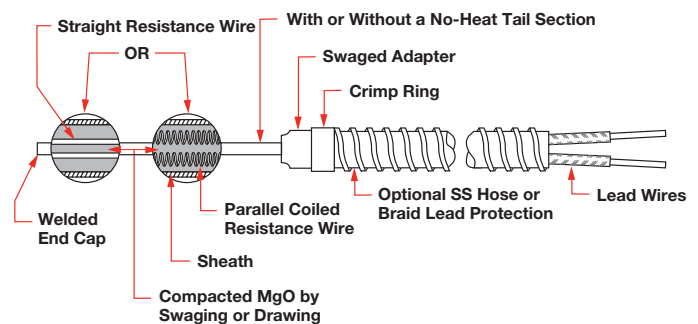
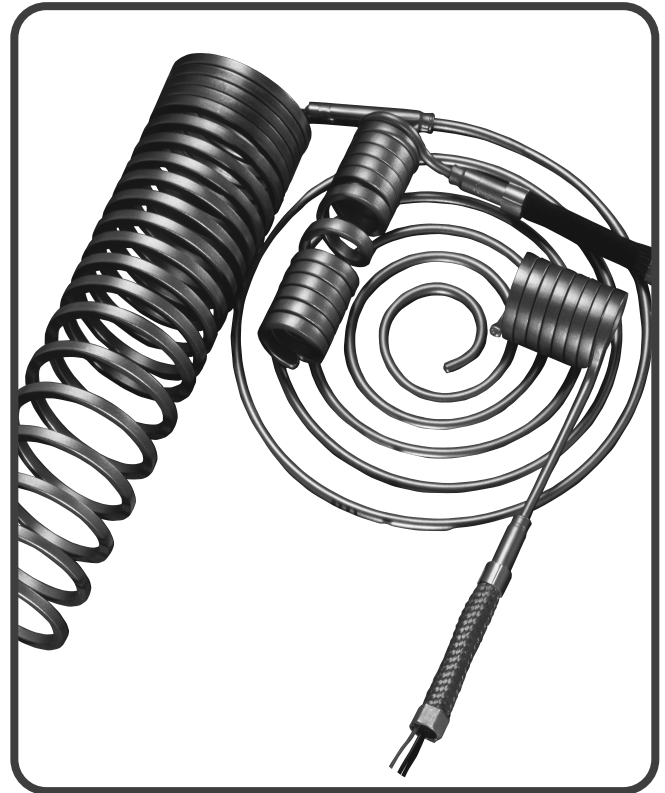

Heater sheath can be brazed

- Allows the permanent attachment of mounted fittings to the heater, contact your Watlow representative

Sizes range from 0.040 in. (1.02 mm) to 0.188 in. (4.8 mm) diameter

- Delivers a high volume of heat into a tiny space

Internal construction options

- Allows for internal thermocouples and no-heat sections (not available in all sizes)



Coil/Cable Heaters

Typical Applications

- Plastic injection molding nozzles
- Semiconductor manufacturing and wafer processing
- Semiconductor pedestal heating and showerhead
- Hot metal forming dies and punches
- Sealing and cutting bars
- Medical, analytical and scientific instruments
- Restaurant and food processing equipment
- Cast-in heaters
- Laminating and printing presses
- Air heating
- Textile manufacturing
- Heating in a vacuum environment

Electrical Data and Coiling Limits

Sheath Diameter		Max. Voltage	Surface Area Per Linear Foot		Min. Bend Radius		Min. Coiled Inside Diameter	
in.	(mm)		in.	(cm)	in.	(mm)	in.	(mm)
0.040 ± 0.002	(1.016 ± 0.051)	48	1.51	(9.740)	1/16	(1.6)	1/8	(3.2)
0.062 ± 0.002	(1.575 ± 0.051)	120	2.34	(15.098)	1/8	(3.2)	1/4	(6.0)
0.094 + 0.002 - 0.003	(2.388 + 0.051 - 0.076)	240	3.54	(22.840)	3/16	(4.8)	3/8	(9.5)
0.102 square ± 0.003	(2.591 ± 0.076)	240	4.90	(31.615)	1/4	(6.0)	1/2	(13.0)
0.102 ± 0.003 x 0.156 ± 0.005 rectangular	(2.591 ± 0.076) x (3.962 ± 0.127)	240	6.19	(39.938)	1/4	(6.0)	1/2	(13.0)
0.125 ± 0.003	(3.175 ± 0.076)	240	4.71	(30.389)	1/4	(6.0)	1/2	(13.0)
0.157 ± 0.004	(3.988 ± 0.102)	240	5.92	(38.196)	5/16	(7.9)	5/8	(15.9)
0.188 + 0.003 - 0.006	(4.775 + 0.076 - 0.152)	240	7.09	(45.745)	3/8	(9.5)	3/4	(19.0)
0.128 square ± 0.003	(3.251 ± 0.076)	240	6.31	(40.712)	1/4	(6.0)	1/2	(13.0)

In most cases 30 W/in² (4.65 W/cm²) is the safe allowable limit for cable watt density. Please contact your Watlow representative prior to ordering >30 W/in² cables.

Resistance/Wattage Tolerance ±10%.

Cable heaters can run on both ac and dc. Contact your Watlow representative for amperage limitations.

Coiling Tolerances

Cable Diameters	Coiled Width Tolerances		Coiled I.D. Tolerances			
	Coiled Width in. (mm)	Tolerances in. (mm)	Coil I.D. Range in. (mm)		Tolerances in. (mm)	
All Diameters	Below 6 (152)	+ 1/8 -1/8 (+3.18 - 3.18)	Below 0.625	(Below 15.88)	+0.000 - 0.015	(+0 - 0.38)
	6 to 10 (152 to 254)	+ 1/8 - 3/8 (+3.18 - 9.53)	0.625 to 0.999	(15.88 to 25.38)	+0.000 - 0.030	(+0 - 0.76)
	Over 10 (Over 254)	+ 1/4 -1/4 (+6.35 - 6.35)	1.000 to 1.999	(25 to 50.78)	+0.000 - 0.062	(+0 - 1.58)
			2.000 to 2.999	(51 to 76.18)	+0.000 - 0.125	(+0 - 3.18)
			3.000 to 3.999	(76 to 101.58)	+0.000 - 0.250	(+0 - 6.35)
			4.000 to 4.999	(102 to 126.98)	+0.000 - 0.375	(+0 - 9.53)
			5.000 and Over	(127 and Over)	+0.000 - 0.500	(+0 - 13.00)

When the O.D. of the coil is required as the critical dimension, it must be specified at the time of ordering so that proper coiling procedures can be determined. I.D. and O.D. dimensions cannot be held on the same unit. Please contact your Watlow representative prior to ordering coiled cable heaters requiring other than standard tolerances.

Cable Straight Length Tolerances

Length	≤ 24 in.	>24 in. ≤ 60 in.	>60 in. ≤ 100 in.	>100 in.
Tolerance	±3/8 in.	±1/2 in.	±1 in.	±1%

Specialty Heaters



Coil/Cable Heaters

Formation Options

Coil Heaters

The coil heater can be tight wound or open pitch.

Lead Orientation Options for Coiled Cable Heaters

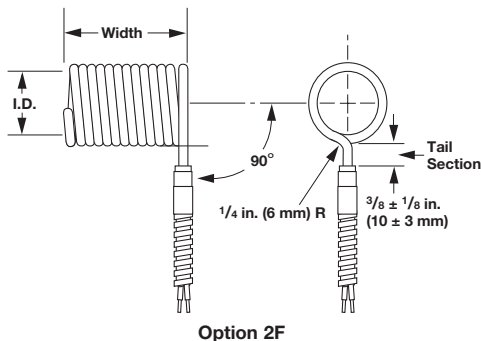
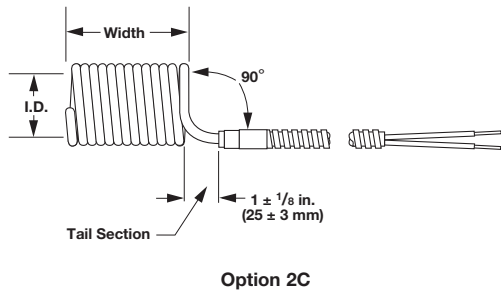
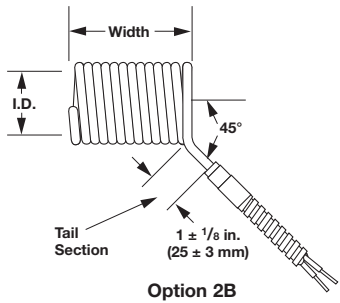
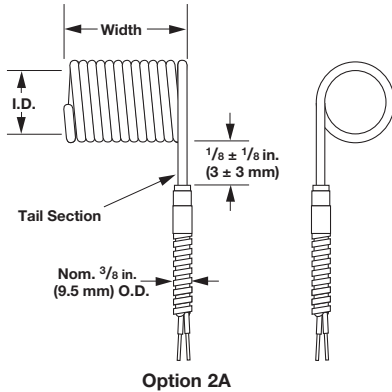

Note: Coiling or complex forming of stock heaters will generally result in increased resistance and reduction in wattage below 10 percent tolerance. Please contact factory before specifying power and resistance tolerance for formed cables.

Closed Coil without Distributed Wattage

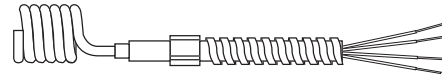

Closed Coil with Distributed Wattage

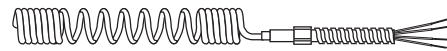

Flat Spiral

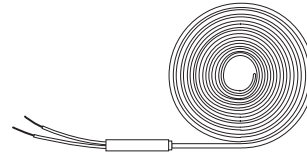

Flat, spiral formations are used to heat flat circular surfaces. This formation is often used in semiconductor and medical applications.

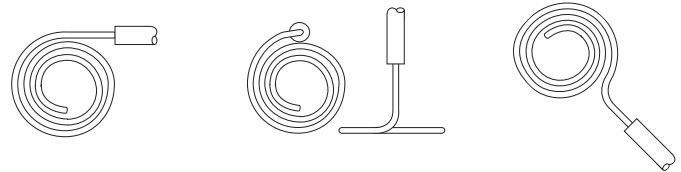

Flat Spiral with 2A Type Lead Orientation

Flat Spiral with 2C Type Lead Orientation

Flat Spiral with 2F Type Lead Orientation

Flat Spiral Inside Diameter Standards						
		Cable Diameter—in.				
		1/16 (0.062)	3/32 (0.094)	1/8 (0.125)	5/32 (0.156)	3/16 (0.188)
Spiral Inside Diameter—in.	5/8 (0.625)	✓	✓	✓		
	3/4 (0.75)		✓	✓	✓	✓
	7/8 (0.875)			✓	✓	
	1 (1.0)			✓	✓	✓
	1 3/16 (1.187)			✓		
	1 1/4 (1.25)			✓		
	1 1/2 (1.5)			✓	✓	✓
	2 (2.0)			✓		
	2 1/2 (2.5)			✓		
	3 (3.0)			✓	✓	✓

Note: Maximum outside diameter is 6 inches.



Coil/Cable Heaters

Formation Options (Continued)

Star Wound

Star wound formations are usually inserted into pipes or ducts and used to heat moving air or liquids. The offset coils increase and induce turbulent flow. This allows the flowing material to have better contact with the heater surface to provide efficient heat transfer.

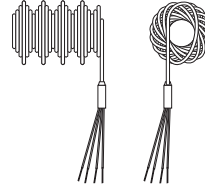

Internal Construction

Sheath with Coiled Internal Resistance Wire

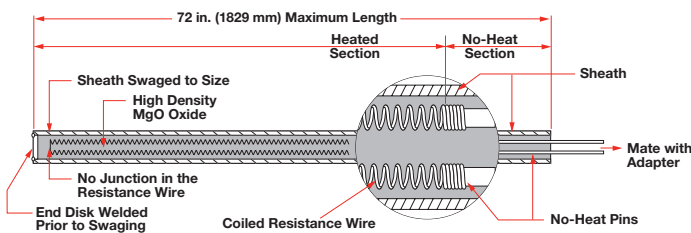

Resistance wire wound into a small coil is loaded into insulating cores, then into metal tubing and swaged to final size. This construction method is called **coil wire or parallel coil**.

The coil method allows for a no-heat section in the sheath. The length of either the heated section or the no-heat section is variable as long as the combined length does not exceed 72 in. (1829 mm). Other features of this construction method include:

- Variable ohms/foot within a minimum and maximum range
- Variable location of the thermocouple junction
- Grounded or ungrounded thermocouple junction
- No-heat sections
- 304 stainless steel
- A variety of diameters and shapes:
 - 0.094 in. (2.4 mm) round
 - 0.125 in. (3.2 mm) round (minimum diameter with internal thermocouple)
 - 0.102 in. (2.6 mm) square
 - 0.128 in. (3.3 mm) square
 - 0.102 in. X 0.156 in. (2.6 mm X 4 mm) rectangular

Sheath with Straight (Uncoiled) Resistance Wire

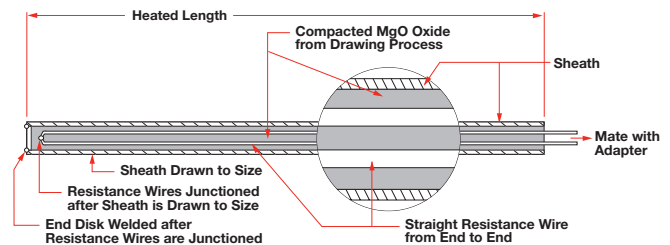

Straight resistance wires are positioned inside a large diameter metal tube. The tube assembly is repeatedly pulled through draw dies until the desired diameter is achieved. Though limited to fixed incremental ohms/foot and without no-heat sections, this **straight wire or drawn cable** construction method allows:

- Essentially no limit on cable length
- Thermocouple junction only at the disk end of the sheath
- Grounded or ungrounded thermocouple junction
- Full length of the sheath is heated
- 304 stainless steel
- A variety of diameters and shapes:
 - 0.040 in. (1.0 mm) round
 - 0.062 in. (1.6 mm) round
 - 0.094 in. (2.4 mm) round
 - 0.125 in. (3.2 mm) round (minimum diameter with internal thermocouple)
 - 0.157 in. (4.0 mm) round
 - 0.188 in. (4.8 mm) round
 - 0.128 in. (3.3 mm) square*
 - 0.102 in. X 0.156 in.* (2.6 mm X 4 mm) rectangular

* Maximum length is 140 in. (3556 mm)



Coil/Cable Heaters

Internal Construction (Continued)

Disk End of Sheath

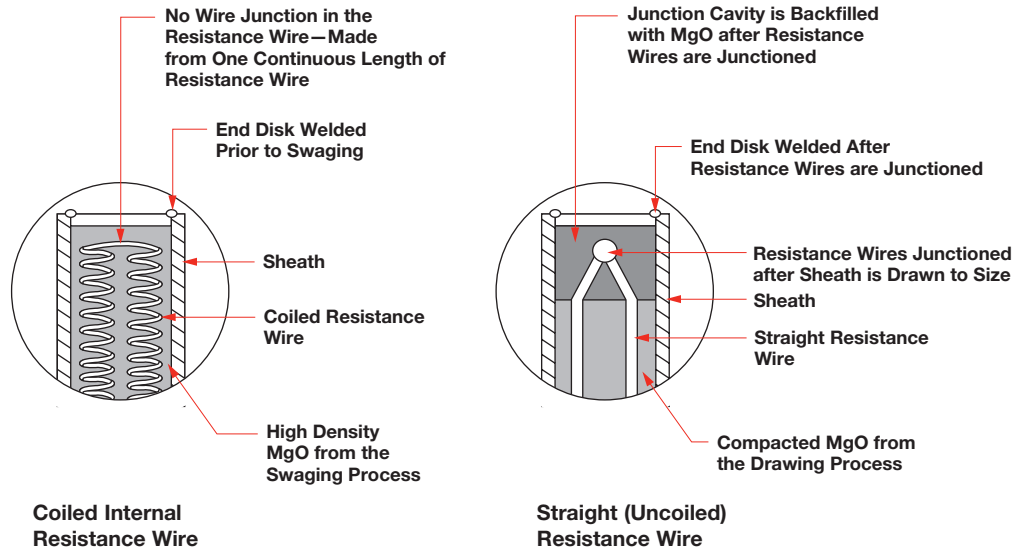

The end of the heater sheath opposite from the lead exit end is called the disk end.

With coil construction methods, the internal resistance wires form a 180° bend inside the sheath and do not require a junction. After the end cap has been welded in place, the entire area at the end of the sheath is swaged to provide maximum density of the magnesium oxide (MgO).

Straight (Uncoiled) Resistance Wire

With straight construction, the internal wires—whether resistance or thermocouple—must be junctioned before the heater sheath can be finished. MgO is removed from the tip of the sheath to expose the wires, which are junctioned by welding. MgO powder is backfilled into the cavity surrounding the junctioned wires and lightly compacted. The end cap is inserted and welded into place.

Thermocouples

Internal thermocouples are available in ASTM Type J or K calibration with both the coil or straight construction methods.

Coil:

- 0.125 in. (3.2 mm) round
- 0.128 x 0.128 in. (3.3 x 3.3 mm) square
- 0.102 x 0.156 in. (2.6 x 4.0 mm) rectangular

Straight:

- 0.125 in. (3.2 mm) round
- 0.157 in. (4.0 mm) round
- 0.188 in. (4.8 mm) round
- 0.128 x 0.128 in. (3.3 x 3.3 mm) square
- 0.102 x 0.156 in. (2.6 x 4.0 mm) rectangular

Specialty Heaters



Coil/Cable Heaters

Options—Internal Construction

Adapters

Adapters are transition sections where lead wires are attached and connected with the internal wires from the heater sheath.

The **positive connection** lap joint brazes or welds the wire lap joint before the adapter is compacted. Positive connection is used in all standard applications and adds protection in high temperature environments.

An extended length adapter collar, or **high temperature** collar, is used as a heat sink enabling the heater to operate in high temperature, demanding applications.

The positive connection and collar are used in conjunction with both power leads and thermocouple leads.

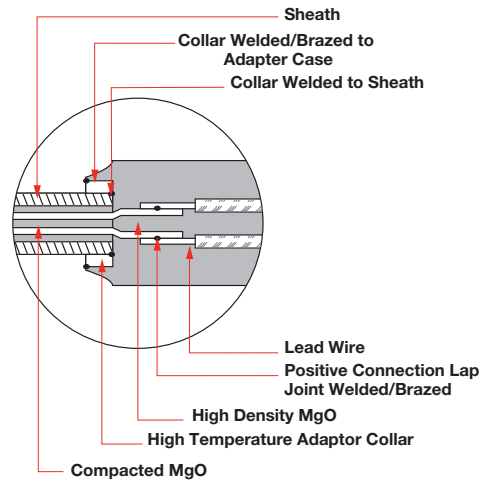

External Construction

Lead Wire

100 percent nickel, copper, nickel plated copper or silver plated copper

Insulation

PTFE, fiberglass or a high temperature variety such as MGT or MGE

Lead Protection

Stainless steel hose, stainless steel braid or fiberglass braid

Contact your Watlow representative for details.

Specialty Heaters



Coil/Cable Heaters

Cable Heater Units (Internal thermocouple is not available)

Straight Cable Length in. (mm)	Volts	Watts	Watt Density W/in ² (W/cm ²)	No-Heat Length in. (mm)	Lead Wire	Part Number
0.062 in. (1.6 mm) Diameter Round (with ±10% wattage tolerance) 0.250 in. x 1.125 in. adapter						
24 (610)	120	240	51 (7.9)	0 (0)	36 in. (914) mm swaged-in fiberglass	62H24A6X-1138
36 (914)	120	400	57 (8.8)	0 (0)		62H36A5X-1015
56 (1422)	120	330	30 (4.7)	0 (0)		62H56A4X-942
65 (1651)	120	500	39 (6.0)	0 (0)		62H65A3X-1111
0.094 in. (2.4 mm) Diameter Round (with ±5% wattage tolerance) 0.132 in. x 1.250 in. adapter— Lead protection not available						
30 (762)	230	125	17 (2.6)	5 (127)	48 in. (1219) mm swaged-in PTFE leads only	94PC30A1X
30 (762)	230	250	34 (5.3)	5 (127)		94PC30A2X
0.125 in. (3.2 mm) Diameter Round (with ±10% wattage tolerance) 0.250 in. x 1.125 in. adapter, *0.375 in. x 2.000 in. adapter						
18 (457)	240	250	35 (5.4)	1.5 (38)	36 in. (914) mm swaged-in fiberglass	125CH18A4X-1066
19 (483)	120	165	21 (3.3)	1.5 (38)		125CH19A1X-879
24 (610)	120	275	29 (4.5)	1.5 (38)		125CH24A1X-1049
24 (610)	240	275	29 (4.5)	1.5 (38)		125CH24A14X-806
38 (965)	240	325	21 (3.3)	1.5 (38)		125CH38A1X-631
38 (965)	120	175	12 (1.9)	1.5 (38)		125CH38A2X-246
47 (1194)	240	260	14 (2.2)	1.5 (38)		125CH47A1X-108
47 (1194)	120	235	12 (1.9)	1.5 (38)		125CH47A2X-182
47 (1194)	120	375	20 (3.1)	1.5 (38)		125CH47A3X-986
47 (1194)	240	345	19 (2.9)	1.5 (38)		125CH47A4X-1081
65 (1651)	240	420	16 (2.5)	1.5 (38)		125CH65A1X-940
65 (1651)	240	675	27 (4.2)	1.5 (38)		125CH65A2X-1115
95 (2413)	240	1000	28 (4.3)	0 (0)		125CH93A1X-1154
126 (3200)	240	1500	30 (4.7)	0 (0)		48 in. (1219) mm swaged-in fiberglass
150 (3810)	240	2000	34 (5.3)	0 (0)	125H150A3A-1168*	
223 (5664)	240	3000	34 (5.3)	0 (0)	125H223A1A-1057*	
0.128 in. (3.3 mm) Square Cross-Section (with ±10% wattage tolerance) 0.250 in. x 1.125 in. adapter						
12 (305)	120	200	36 (5.6)	1.5 (38)	36 in. (914) mm swaged-in fiberglass	125PS12A24A-647
12 (305)	240	200	36 (5.6)	1.5 (38)		125PS12A23A-155
20 (508)	120	300	31 (4.8)	1.5 (38)		125PS20A37A-537
20 (508)	240	300	31 (4.8)	1.5 (38)		125PS20A38A-142
30 (762)	120	450	30 (4.7)	1.5 (38)		125PS30A47A-159
30 (762)	240	450	30 (4.7)	1.5 (38)		125PS30A48A1019
38 (965)	240	600	31 (4.8)	1.5 (38)		125PS38A23A-562

Note: Lead protection is available upon request.



Coil/Cable Heaters

Cable Heater Units (Type J internal thermocouple)

Straight Cable Length in. (mm)	Volts	Watts	Watt Density W/in ² (W/cm ²)	No-Heat Length in. (mm)	Lead Wire	Part Number
0.125 in. (3.2 mm) Diameter Round (with ±10% wattage tolerance), thermocouple located in center of heated section, 0.250 in. x 1.125 in. adapter						
24 (610)	120	275	29 (4.5)	1.5 (38)	48 in. (1219) mm swaged-in fiberglass	125CH24A13X
38 (965)	120	175	12 (1.9)	1.5 (38)		125CH38A18X
47 (1194)	120	235	13 (2.0)	1.5 (38)		125CH47A21X
65 (1651)	240	675	26 (4.0)	1.5 (38)		125CH65A26X
0.157 in. (4 mm) Diameter Round (with ±10% wattage tolerance), thermocouple located at the disk end of the cable, 0.375 in. x 2.000 in. adapter						
124 (3150)	240	1500	25 (3.9)	0 (0)	48 in. (1219) mm swaged-in fiberglass	157CH124AX
150 (3810)	240	2000	27 (4.2)	0 (0)		157CH150AX
220 (5588)	240	3000	28 (4.3)	0 (0)		157CH220AX
0.128 in. (3.3 mm) Square Cross-Section (with ±10% wattage tolerance), thermocouple located in center of heated section, 0.250 in. x 1.125 in. adapter						
12 (305)	240	200	36 (5.6)	1.5 (38)	48 in. (1219) mm swaged-in fiberglass	125PS12A22A
20 (508)	120	300	31 (4.8)	1.5 (38)		125PS20A35A
20 (508)	240	300	31 (4.8)	1.5 (38)		125PS20A36A
30 (762)	240	450	30 (4.7)	1.5 (38)		125PS30A46A
38 (965)	240	600	31 (4.8)	1.5 (38)		125PS38A24A

Note: Lead protection is available upon request.

