

VPAC-BT

Remote Mount Transformer

Data Sheet

General Description

The BT card (Watlow P/N 08-5406) is time proportioning with a variable (very fast) time base. At 50% power, one full cycle is ON, and one full cycle is OFF. At 25% power, it is ON one cycle and OFF for three. At 90%, it is ON nine cycles and OFF for one. As the command signal gets farther from 50% power, the time base gets longer. The maximum time base resolution is 1 in 360 ac cycles. The BT card is factory set for 4-20mA into 250Ω. It can be changed to a voltage input by removing the 300Ω, R22 resistor, located on the lower right corner of the card. Without R22, it is a 5K input impedance. See the illustration on the reverse side. Bias and gain pots allow the card to be adjusted for any voltage from 0-3V_{dc} to 15V_{dc} or current between 0 to 25mA.

BT card power supply requirements are 24V_{ac} center tap transformer secondary. Transformer primary must be connected to the same line phase as the heater load. For example, if the heater is powered by L1 and L2, then the power transformer must also be connected to L1 and L2. See the illustration on the reverse side.

Dimensions

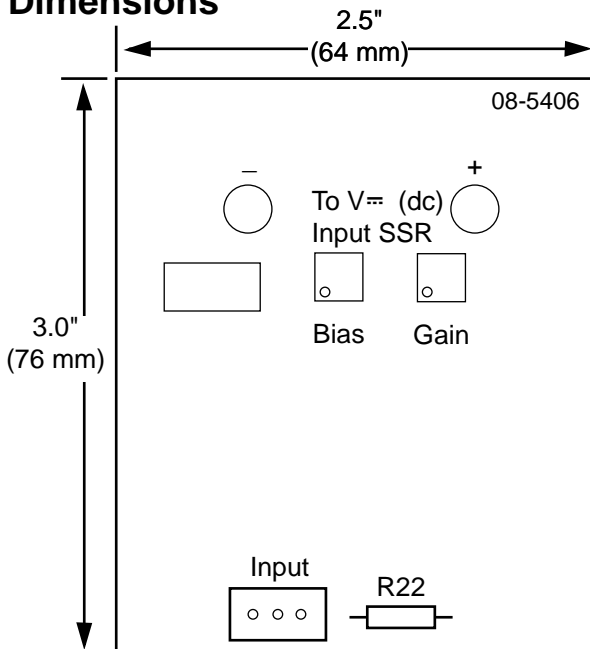

Specifications

(1276)

Input

- Process input factory set @ 4-20mA_{dc}
- Input impedance 250Ω (clip resistor for 5KΩ voltage input), or manual control input

Output

- Burst firing control, variable time base
- TTL compatible (5V logic) at about 5mA @ 5V. Will drive one industry standard 3-32V_{dc} input random fire SSR. For single phase only.

Line Voltage Power

- 50/60 Hz V_{ac} line frequency
- Voltage ±10%, 120, 208, 240, 277, 380, 415, 480V_{ac}. Power transformer is supplied with the BT card. When ordering, specify power supply voltage and line frequency.

Line Voltage Compensation

- 10%Δ in line, 2%Δ in load in the 30% to 70% power region.

Input to Output Linearity

- 2%, 30% to 70% power region

Operating Environment

- 32 to 122°F (0 to 50°C)

Storage Temperature

- -40 to 185°F (-40 to 85°C)

Options

- Manual control kit for voltage input cards (1KΩ potentiometer) #08-5362. Includes dial, knob, 1KΩ pot and wiring.

Ordering Information

- Watlow P/N 08-5406



Watlow Controls

1241 Bundy Blvd., P.O. Box 5580
Winona, MN 55987-5580

Phone: 507-454-5300, Fax: 507-452-4507



Wiring Diagram for VPAC-BT Remote Mount Transformer

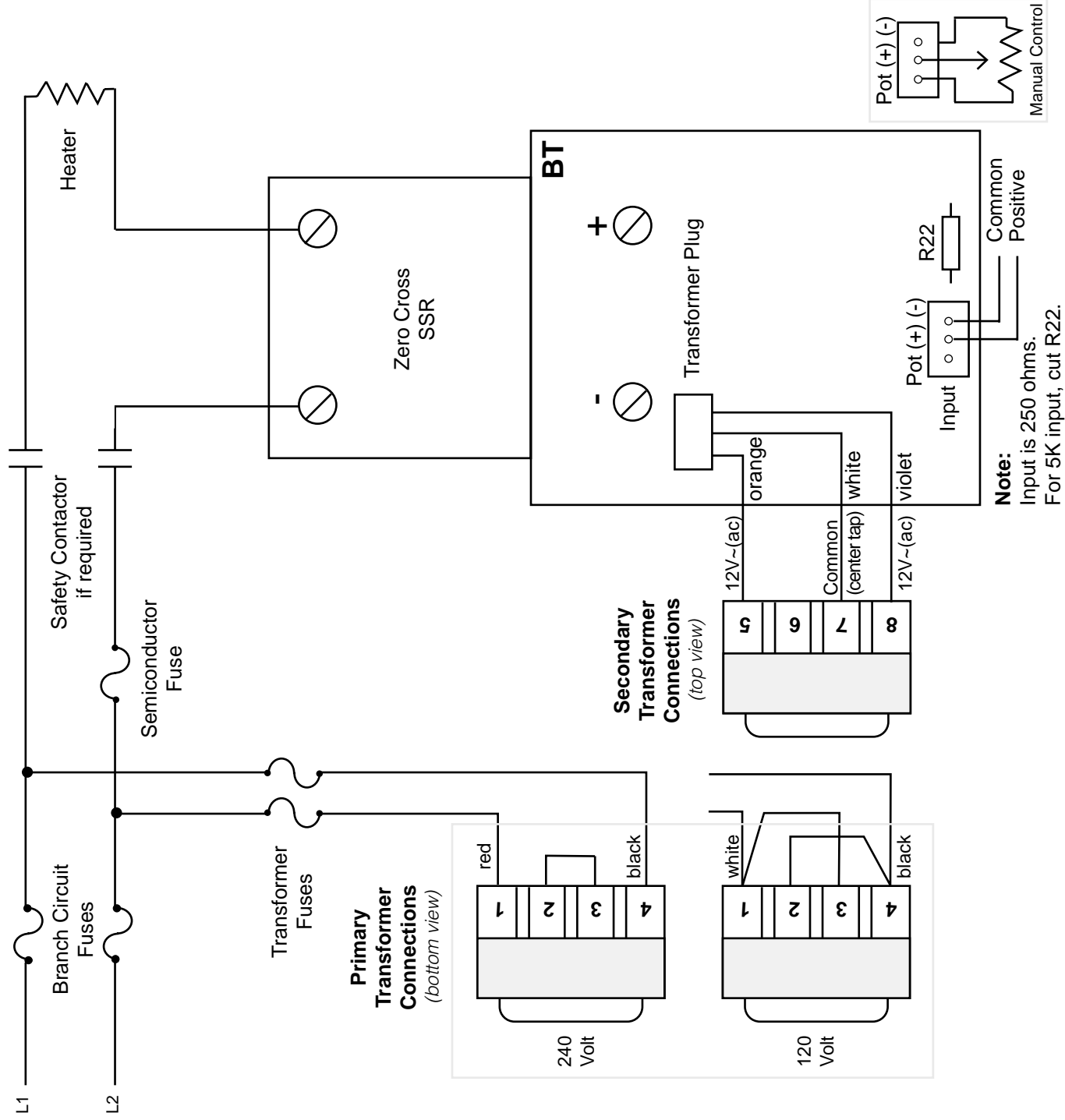

Note: The controls transformer must be on the same phase as the load. See wiring diagram. All hot lines to the transformer should be fused at 1 amp with the proper line voltage.

For manual control, a 1KΩ potentiometer may be connected to the AT card input terminals. Watlow offers a Manual Control Kit, P/N 08-5362. Using this potentiometer requires removing the 5KΩ, R2 resistor for higher impedance.

Bias and gain adjustment is required when changing from 4-20mA input to a manual control input or a voltage input.