

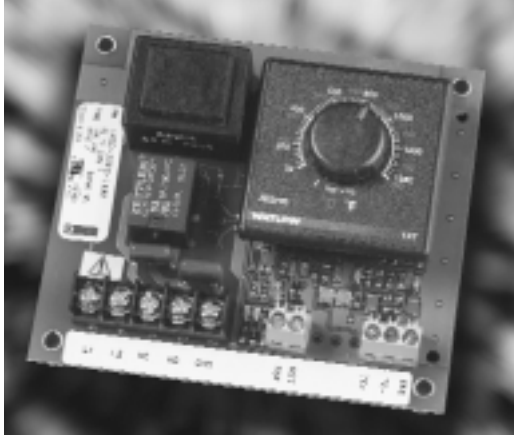

# Series 147

## User's Manual



### Temperature Limit



ISO 9001



**Watlow Controls**

1241 Bundy Boulevard, P.O. Box 5580, Winona, Minnesota USA 55987-5580  
Phone: 507/454-5300, Fax: 507/452-4507, Internet: <http://www.watlow.com>

0600-0004-0011 Rev E

August 2000

Supersedes: 0600-0004-0011 Rev D

**\$5.00 Made in the U.S.A.**



Printed on Recycled Paper  
10% Postconsumer Waste

## General Description

Watlow's Series 147 is an open-board temperature limit with a thermocouple or RTD sensor input.

The Series 147 is designed to meet the needs of a wide range of temperature limit applications. Installation and setup are simple and easy, using basic hand tools. Factory selectable options include high or low limit with either manual or automatic reset on power loss.

The Series 147 has an LED output status indication and can be ordered with an integral or a fixed set point.

## Specifications

(1885)

### Control Mode

- High or low limit, factory selectable
- Manual or automatic reset on power loss, factory selectable
- Latching alarm with manual reset on overtemperature
- Customer-supplied reset switch

### Operator Interface

- LED indication of output status
- Dial scale calibrated to compensate for sensor non-linearities
- Integral set point
  - Dual temperature scale (°F and °C)
- Fixed set point
  - Manufactured to specified value

### Input

- Thermocouple or platinum RTD available
- Thermocouple with automatic cold junction compensation
- Thermocouple may be isolated or grounded
- Thermocouple and RTD break protection de-energizes output
- 2- or 3-wire RTD input, 100Ω, 500Ω, or 1000Ω @ 0°C calibrated for 0.003850Ω/°C curve, factory selectable

### Output

- Electromechanical relay, 8A, Form C, SPDT: 8A @ 240V~ resistive, 8A @ 28V= (dc) resistive, 275VA pilot duty rated

### Accuracy

#### Adjustable Set Point

- Calibration accuracy: ±1% of span, at 77°F ±5°F (25°C ± 3°C) ambient and rated line voltage ± 1%
- Set point accuracy: ±3% of dial scale
- Accuracy span: 1000°F (540°C) minimum

#### Fixed Set Point

- Calibration accuracy: ±10°F/±6°C of setting, at 77°F ±5°F (25°C ±3°C) ambient and rated line voltage ±1%

### Agency Approvals

- CE: EN61010 - Safety  
EN61326 - Industrial Immunity, Class B Emissions  
Installation Category 2, Pollution Degree 2
- 873 Recognized, File #E43684
- Recognized to C22.2 No. 24, File #E43684
- Approved for use in commercial cooking applications
- FM Class 3545

### Terminals

- Sensor input and remote setpot
  - Screw clamp terminal: 12-26 gauge wire
- Power input and control output
  - #6 screws on barrier strip

### Power

- 120V~, +10%/-15%, 50/60 Hz
- 230V~ to 240~, +10%/-15%, 50/60 Hz
- 10VA maximum power

### Operating Environment

- 32 to 131°F (0 to 55°C)
- 0 to 90% RH, non-condensing
- Storage temperature: -4 to 185°F (-20 to 85°C)

### Dimensions

- Width: 4.5 in (114 mm)
- Length: 4.0 in (102 mm)
- Depth: 1.5 in (38 mm)

### Weight

- 0.7 lb (0.3kg)

UL® is a registered trademark of Underwriter's Laboratories, Inc.

Note: Specifications subject to change without notice.

## Ordering Information

(1886)

147 - - - 0 0 0

### Output Type

E = Electromechanical relay, 8A,  
Form C

### Line Voltage

1 = 120V~  
2 = 230V~ to 240V~

### Input and Range

#### Type J

601 = 32 to 600°F (0 to 315°C)  
602 = 32 to 1382°F (0 to 750°C)  
609 = 50 to 150°F (10 to 66°C)  
614 = Fixed at 750°F (399°C)  
615 = Fixed at 600°F (315°C)

#### Type K

603 = 32 to 2282°F (0 to 1250°C)  
611 = 32 to 1112°F (0 to 600°C)  
612 = 32 to 482°F (0 to 250°C)  
613 = 0 to 2500°F (-17 to 1371°C)

#### Type T

604 = 150 to 662°F (66 to 350°C)  
605 = -328 to 150°F (-200 to 66°C)  
610 = -125 to 425°F (-87 to 218°C)

#### Type R

608 = 32 to 2732°F (0 to 1500°C)

#### Type S

607 = 32 to 2732°F (0 to 1500°C)

#### RTD (100Ω)

101 = -100 to 1112°F (-73 to 600°C)  
103 = 32 to 482°F (0 to 250°C)

#### Limit Mode

1 = High limit with manual reset on power loss  
2 = Low limit with manual reset on power loss  
3 = High limit with automatic reset on power loss  
4 = Low limit with automatic reset on power loss

**NOTE: Electromechanical relays are warranted for 100,000 closures only. Solid state switching devices recommended for applications requiring extended service life.**

**NOTE: Conformal coated product is available; consult factory.**

**NOTE: This output should be used with inductive loads.**

**NOTE: User documentation may be available in French, German, Spanish, Italian, and Dutch, as well as English. Check Watlow's website ([www.watlow.com/](http://www.watlow.com/)) for availability. Specify language at time of order.**

## Warranty

The Series 147 is warranted to be free of defects in material and workmanship for 36 months after delivery to the first purchaser for use, providing that the unit has not been misapplied. Since Watlow has no control over its use or misuse, we cannot guarantee against failure. Watlow's obligations hereunder, at Watlow's option, are limited to replacement or refund of purchase price of a unit which upon examination proves to be defective within the warranty period. This warranty does not apply to damage resulting from transportation, alteration, misuse or abuse.

## Returns

- Call or fax Customer Service for a Return Material Authorization (RMA) number before returning a product.
- Put the RMA number on the shipping label, and also a description of the problem.
- A 20% of net price restocking charge applies to all standard units returned to stock.

#### Contact

- Phone: +1 (507) 454-5300
- Fax: +1 (507) 452-4507

## Technical Support

If you encounter a problem with your Watlow controller, verify that your wiring is correct for your specific model number. If the problem persists, an Application Engineer can discuss your application with you.

Before calling, please have the complete model number and user's manual available. You can get technical support by dialing +1 (507) 494-5656, 7 a.m. to 7 p.m. Central Standard Time.

The Series 147 User's Manual is copyrighted by Watlow Winona, Inc., © August 2000, with all rights reserved. (1884)

## Troubleshooting

Problem	Probable Cause	Action
The load will not turn on.	An open sensor	Repair or replace.
	The load circuit is open.	Check the fuses, circuit breakers, load and wiring.
	The ac input is not connected or is connected improperly.	Check the ac input connections. If not present, connect per Power Wiring, page 2.
The load will not turn off.	The polarity is reversed on the thermocouple.	Connect according to input wiring directions, page 3.
	A faulty unit.	Remove power to the controller and the controller from the system. Apply power to the system with the controller removed. If the load turns off, return the controller to the factory. If the load remains on, there are other problems in the system that must be resolved. Consult the factory.

## Installation

Use the following procedure to mount and install the Watlow Series 147 temperature limit control.

1. Locate and drill four 0.156 in (4 mm) holes in the desired panel location. See Figure 2 for hole locations.
2. Mount the Series 147 using four #6 screws.
3. Connect the sensor, load, and power as illustrated in the wiring diagrams on pages 2 and 3.

## Dimensions

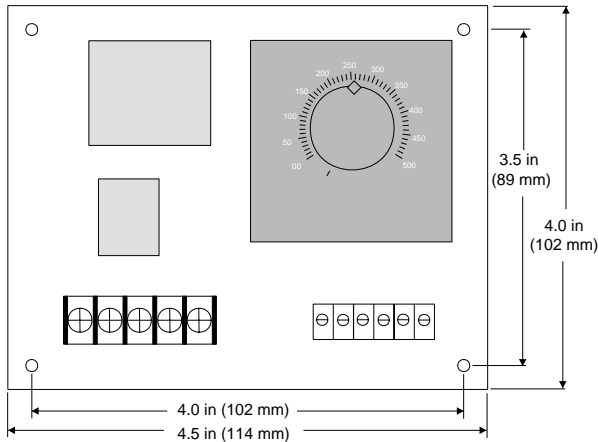

Figure 4a — Series 147 dimensions.

## Wiring Guidelines

- Use the correct sensor type per the model number on the unit sticker.
- Use the proper thermocouple or RTD polarity.
- Insulate the thermocouple mounting from the mounting surface to prevent heat migration input errors.
- Thermocouple leads should be twisted pair wire and routed separately from any other lines.
- In electrically noisy environments (heavy switching of contactor, motors, solenoids, etc.) use shielded thermocouple lead wire with the shield connected at the sensor end only.
- All wiring and fusing must conform to the National Electric Code (NEC) NFPA70 and any other locally applicable codes.
- Fuse the independent load voltage on the L1 (hot) side and connect it to the common (COM) side of the relay.
- Long lead lengths create electrical resistance. When using a two-wire RTD, there will be an additional input error for every 1 $\Omega$  of lead length resistance. That resistance when added to the resistance of the RTD element, can result in erroneous input to the temperature limit. To overcome this problem, use a three-wire RTD sensor, which compensates for lead length resistance. When extension wire is used for a three-wire RTD, all three extension wires must have the same electrical resistance (i.e. same gauge, copper stranded).

## Safety Information

Note, caution and warning symbols appear throughout this book to draw your attention to important operational and safety information.

A “NOTE” marks a short message to alert you to an important detail.

A “CAUTION” safety alert appears with information that is important for protecting your equipment and performance.

A “WARNING” safety alert appears with information that is important for protecting you, others and equipment from damage. Pay very close attention to all warnings that apply to your application.

The  symbol (an exclamation point in a triangle) precedes a general CAUTION or WARNING statement.

The  symbol (a lightning bolt in a triangle) precedes an electric shock hazard CAUTION or WARNING safety statement.

## Power Wiring

120V~ 147 \_ - 1 \_ \_ - 0000

230V~ 147 \_ - 2 \_ \_ - 0000

**NOTE:** The line voltage is specified by your model number.

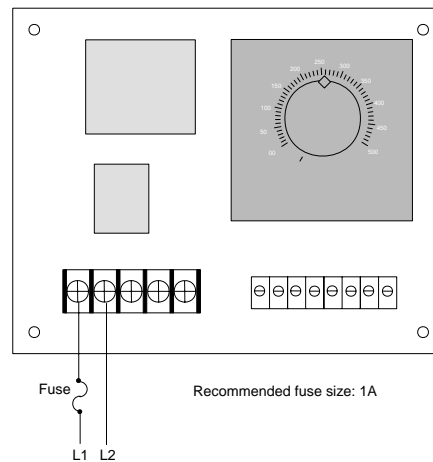

Figure 4b — Power wiring.



**WARNING:** To avoid potential electric shock, use National Electrical Code safety practices when wiring and connecting this unit to a power source and to electrical sensors or peripheral devices. Failure to do so could result in injury and death.

All wiring and fusing must conform to the National Electric Code and to any locally applicable codes. Failure to comply with these recommendations could result in damage to equipment and property, and injury to personnel.



**CAUTION:** The Series 147 temperature limit should be mounted in an inconspicuous location to discourage unauthorized changes to the set point. Only approved and appropriate personnel should have the authority to change the set point on the limit switch. Failure to comply with these recommendations could result in damage to equipment and property, and injury to personnel.



**CAUTION:** Applying incorrect voltage may result in irreversible damage to the controller.

# Declaration of Conformity

## Series 147



**WATLOW WINONA**

1241 Bundy Boulevard

Winona, Minnesota 55987 USA

Declares that the following product: **English**  
Designation: Series 147  
Model Number(s): 147E - (1 or 2) (100-999) - (1, 2, 3, or 4) (0 or 2) (any 2 letters or numbers)  
Classification: Installation Category II, Pollution Degree II  
Rated Voltage: 120 or 240V~  
Rated Frequency: 50/60 Hz  
Rated Power Consumption: 10VA maximum  
Meets the essential requirements of the following European Union Directive(s) using the relevant section(s) of the normalized standards and related documents shown:

**89/336/EEC Electromagnetic Compatibility Directive**  
**EN 61326: 1997 Electrical equipment for measurement, control and laboratory use - EMC requirements (Emissions Class B)**  
EN 61000-3-2: 1995 Limits for harmonic current  
EN 61000-3-3: 1995 Limitations of voltage fluctuations and flicker  
EN 61000-4-2: 1995 Electrostatic discharge  
EN 61000-4-3: 1997 Radiated immunity  
EN 61000-4-4: 1995 Electrical fast transients  
EN 61000-4-5: 1995 Surge immunity  
EN 61000-4-6: 1994 Conducted immunity  
EN 61000-4-11: 1994 Voltage dips, short interruptions and voltage variations immunity  
ENV 50204: 1995 Cellular phone

**73/23/EEC Low-Voltage Directive**  
**EN 61010-1: 1993 Safety requirements for electrical equipment for measurement, control, and laboratory use, Part 1: General requirements**

Déclare que le produit suivant : **Français**  
Désignation : Série 147  
Numéro(s) de modèle(s) : 147E - (1 ou 2) (100-999) - (1, 2, 3 ou 4) (0 ou 2) (deux lettres ou chiffres quelconques)  
Classification : Installation catégorie II, degré de pollution II  
Tension nominale : 120 ou 240V~  
Fréquence nominale : 50/60 Hz  
Consommation d'alimentation nominale : 10 volt-ampères maximum  
Conforme aux exigences de la (ou des) directive(s) suivante(s) de l'Union Européenne figurant aux sections correspondantes des normes et documents associés ci-dessous :

**89/336/EEC Directive de compatibilité électromagnétique**  
**EN 61326: 1995 Appareillage électrique pour la mesure, la commande et l'usage de laboratoire — Prescriptions relatives à la Compatibilité Electro Magnétique (Émissions classe B)**  
EN 61000-3-2 : 1995 Limites d'émission de courant harmonique  
EN 61000-3-3 : 1995 Limites de fluctuation de tension  
EN 61000-4-2 : 1995 Décharge électrostatique  
EN 61000-4-3 : 1997 Insensibilité à l'énergie rayonnée  
EN 61000-4-4 : 1995 Courants électriques transitoires rapides  
EN 61000-4-5 : 1995 Insensibilité aux surtensions  
EN 61000-4-6 : 1996 Insensibilité à l'énergie par conduction  
EN 61000-4-11 : 1994 Insensibilité aux chutes subites, aux courtes interruptions et aux variations de tension  
ENV 50204 : 1995 Téléphone cellulaire

**73/23/EEC Directive liée aux basses tensions**  
**EN 61010-1 : 1993 Exigences de sécurité pour le matériel électrique de mesure, de commande et de laboratoire, Partie 1 : Exigences générales**

(1929)

Erklärt, daß das folgende Produkt: **Deutsch**  
Beschreibung: Serie 147  
Modellnummer(n): 147E - (1 oder 2) (100-999) - (1, 2, 3 oder 4) (0 oder 2) (2 beliebige Buchstaben oder Ziffern)  
Klassifikation: Installationskategorie II, Emissionsgrad II  
Nennspannung: 120 oder 240V~  
Nennfrequenz: 50/60 Hz  
Nominaler Stromverbrauch: Maximaler 10VA  
Erfüllt die wichtigsten Normen der folgenden Anweisung(en) der Europäischen Union unter Verwendung des wichtigsten Abschnitts bzw. der wichtigsten Abschnitte der normalisierten Spezifikationen und der untenstehenden einschlägigen Dokumente:

**89/336/EEC Elektromagnetische Übereinstimmungsanweisung**  
**EN 61326: 1997 Elektrogeräte zur Messung, Regelung und zum Laboreinsatz EMC-Richtlinien (Emissions Klasse B)**  
EN 61000-3-2: 1995 Grenzen der Oberwellenstromemissionen  
EN 61000-3-3: 1995 Grenzen der Spannungsschwankungen  
EN 61000-4-2: 1995 Elektrostatische Entladung  
EN 61000-4-3: 1997 Strahlungsimmunität  
EN 61000-4-4: 1995 Elektrische schnelle Stöße  
EN 61000-4-5: 1995 Spannungsstoßimmunität  
EN 61000-4-6: 1994 Störimmunität  
EN 61000-4-11: 1994 Immunität gegen Spannungsgefälle, kurze Unterbrechungen und Spannungsabweichungen  
ENV 50204: 1995 Mobiltelefon

**73/23/EEC Niederspannungsrichtlinie zu entsprechen**  
**EN 61010-1: 1993 Sicherheitsrichtlinien für Elektrogeräte zur Messung, zur Steuerung und im Labor, Teil 1: Allgemeine Richtlinien**

Declara que el producto siguiente: **Español**  
Designación: Serie 147  
Números de modelo: 147E - (1 ó 2) (100-999) - (1, 2, 3 ó 4) (0 ó 2) (Cualquier combinación de dos letras)  
Clasificación: Categoría de instalación II, grado de contaminación ambiental II  
Tensión nominal: 120 ó 240V~  
Frecuencia nominal: 50/60 Hz  
Consumo nominal de energía: 10 VA máximo  
Cumple con los requisitos esenciales de las siguientes Directivas de la Unión Europea, usando las secciones pertinentes de las reglas normalizadas y los documentos relacionados que se muestran:

**89/336/EEC - Directiva de Compatibilidad Electromagnética**  
**EN 61326: 1997 Equipo eléctrico para medición control y uso en laboratorios - Requisitos de compatibilidad electromagnética (Emisiones Clase B)**  
EN 61000-3-2 1995 Límites para emisiones de corriente armónica  
EN 61000-3-3 1995 Limitaciones de fluctuaciones del voltaje  
EN 61000-4-2: 1995 Descarga electrostática  
EN 61000-4-3: 1997 Inmunidad radiada  
EN 61000-4-4: 1995 Perturbaciones transitorias eléctricas rápidas  
EN 61000-4-5: 1995 Sobretensión  
EN 61000-4-6: 1994 Inmunidad conducida  
EN 61000-4-11: 1994 Caídas de tensión, interrupciones breves y variaciones de tensión  
ENV 50204: 1995 Teléfono portátil

**73/23/EEC Directiva de Baja Tensión**  
**EN 61010-1: 1993 Requerimientos de seguridad para equipos eléctricos de medición, control y uso en laboratorios, Parte 1: Requerimientos generales**

William R. Blaisdell Winona, Minnesota, USA  
Name of Authorized Representative Place of Issue

Plant Manager August 18, 2000  
Title of Authorized Representative Date of Issue

Signature of Authorized Representative

# Input Wiring

## Thermocouple

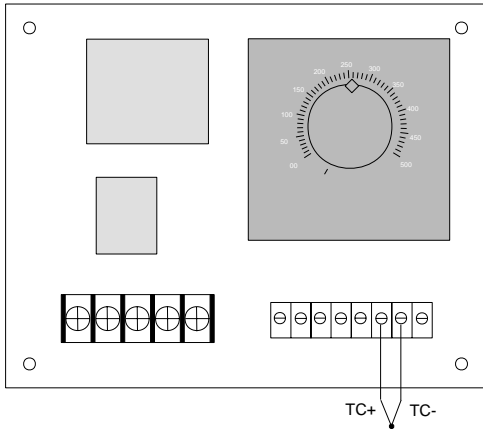
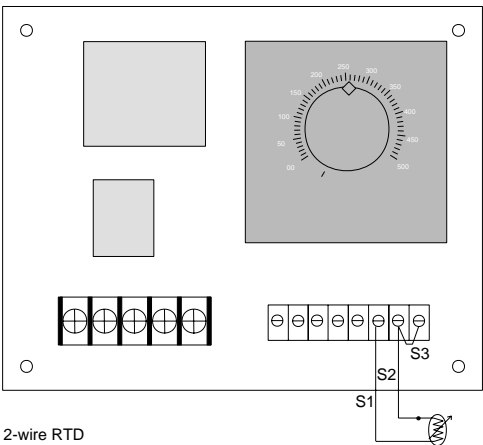
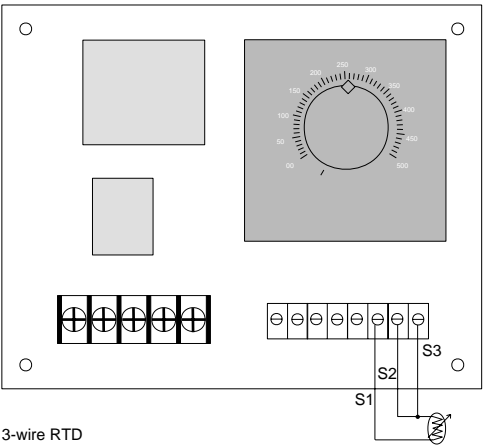

Figure 5a — Thermocouple wiring.

## 2- and 3-wire RTD



2-wire RTD



3-wire RTD

Figure 5b — 2- and 3-wire RTD wiring.

NOTE: 2- or 3-wire RTD input, platinum 100Ω @ 0°C calibrated for 0.003850Ω/Ω°C curve.

# Output Wiring

## Electromechanical Relay, Form C

8A 147E - - - - - 00

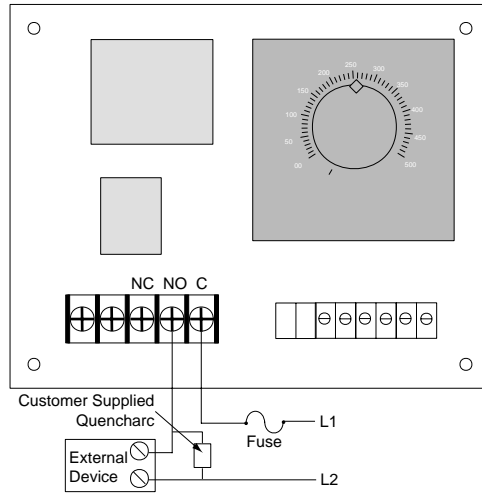

Figure 5c — Electromechanical relay wiring.

⚠ NOTE: Switching inductive loads (relay coils, solenoids, etc.) with the mechanical relay, switched dc or solid-state relay output options requires use of an R.C. Suppressor. Watlow carries the R.C. suppressor Quencharc brand name, which is a trademark of ITW Paktron. Watlow Part No. 0804-0147-0000.

# Remote Reset

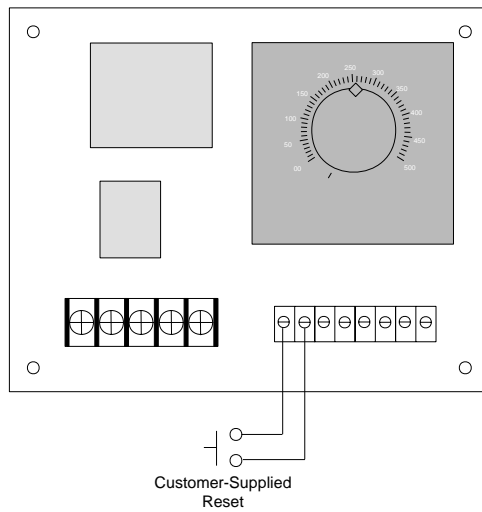

Figure 5d — Reset wiring.

NOTE: Only the use of a momentary switch is valid for FM approval.

NOTE: Reset is customer-supplied.

# System Example

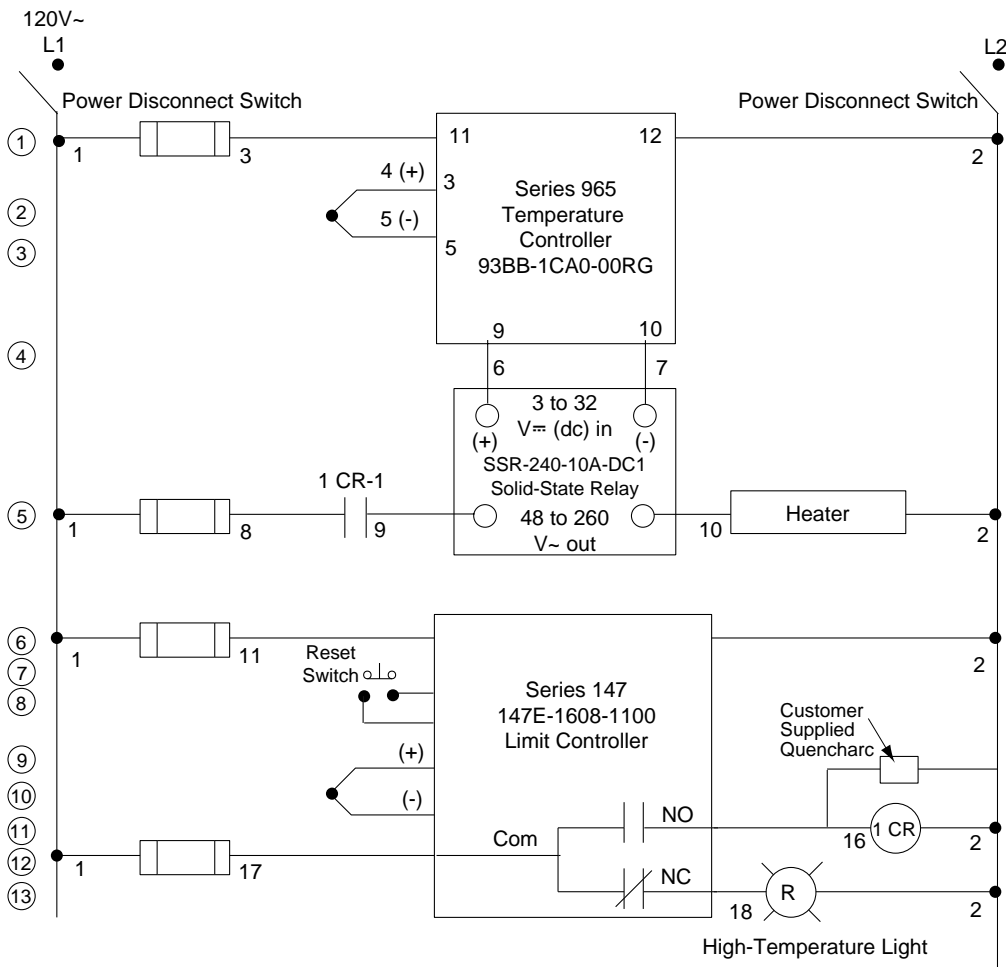
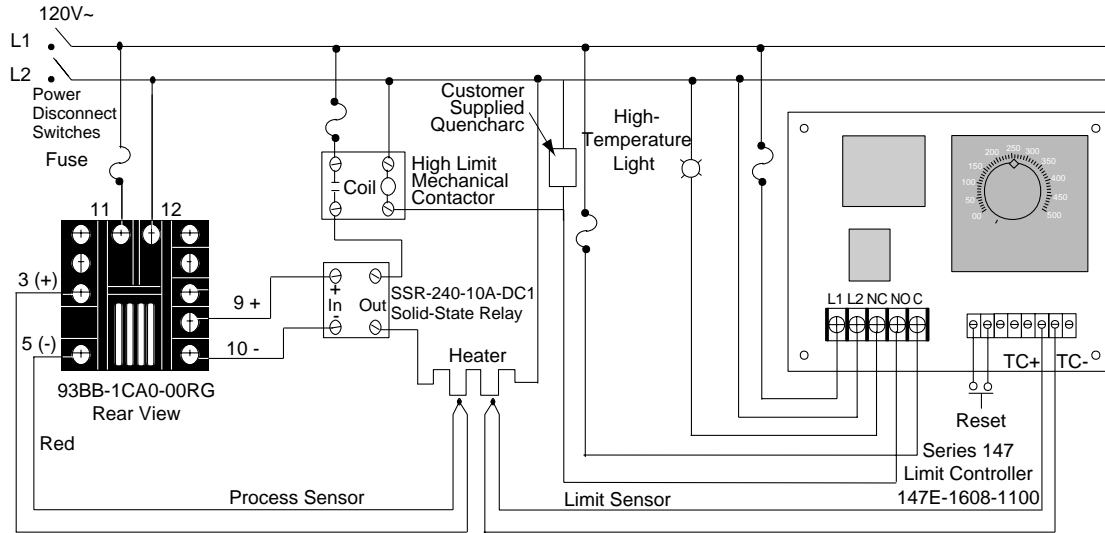

Figure 4 — System wiring examples.