

EXACTSENSE® Thermocouple

Sensor Provides Accurate, Rapid Response Exhaust Gas Temperature Measurements for Diesel Engine After-Treatment Systems

The EXACTSENSE® thermocouple from Watlow® provides the accuracy, response time and durability required to help manufacturers improve their diesel after-treatment system performance. This sensor is designed to meet demanding global emission requirements for over-the-road medium and heavy-duty vehicles and off-road construction, mining, agriculture, marine and locomotive equipment. It is available with a variety of standard options to meet specific manufacturer requirements.

Electronics within a molded connector housing convert the EXACTSENSE thermocouple signal to either an analog or digital output signal that is compatible with the engine control unit (ECU). Integrating the sensor with electronics enables diagnostic capabilities, improves accuracy and enhances connectivity. Up to three sensing points can be attached to a single electronic housing for cost efficiency.

The EXACTSENSE sensor incorporates the WATCOUPLE™ thermocouple to provide stability and longevity at high temperatures. Built using the most durable materials, it is an ideal solution for burner, flame and turbo applications. Compacted mineral insulated thermocouple construction enables a closed tip configuration to deliver exceptional response time and accuracy over the life of the engine.

Sensor probe lengths are available up to 200 millimeters to improve accuracy of temperature measurements in larger pipe diameters requiring long immersion depths. The combination of fast response, accuracy and long immersion depths help EXACTSENSE optimize diesel after-treatment system performance.



Features and Benefits

Integrated electronics with the sensor

- Simplify the connection to the ECU by offering compatibility with a wide variety of output signals including:
 - Control Area Network (CAN) J1939
 - Pulse Width Modulated (PWM)
 - Local Interconnect Network (LIN)
 - Analog 0-5V
- Permit three sensing points to be connected to one electronic housing for cost efficiency
- Enable availability of advanced diagnostic messages to ensure optimum system performance
- Accommodate additional sensors without requiring additional input/output (I/O)

WATCOUPLE thermocouple technology

- Provides reliability in rugged environment
- Accurate and stable temperature measurement over the life of the sensor
- Operates at a wide range of temperatures
- Provides longer sensor life

Tapered tip construction

- Provides industry-leading response time
- Increases life of sensors due to closed tip construction

Long immersion depth

- Improves detection of actual process temperatures

Typical Applications

- Diesel particulate filter (DPF)
- Diesel oxidation catalyst (DOC)
- Selective catalytic reduction (SCR)
- Exhaust gas recirculation (EGR)
- Lean nitrogen oxides (NOx) trap (LNT)
- Turbocharger
- Burner
- Reformer

Watlow® and EXACTSENSE® are registered trademarks of Watlow Electric Manufacturing Company.

WATCOUPLE™ is a trademark of Watlow Electric Manufacturing Company.

Haynes® is a registered trademark of Haynes International, Inc.

Tefzel® is a registered trademark of E.I. duPont de Nemours & Company.

©2010, 2011 Watlow Electric Manufacturing Company, all rights reserved.



RIC-ESTC-0411

Specifications

Sensor Type

- Mineral insulated thermocouple

Output Options

- CAN J1939
- PWM
- LIN 2.1 or 1.3 compatible
- Analog 0-5V ratiometric (RAVS)
- Analog 0-5V non-ratiometric (AVS)

Supply Voltage

- CAN: 12V Battery
- PWM: Regulated 5V and 8V
- LIN: 12V Battery
- Analog: Regulated 5V

Output Communication Speed

- CAN: 250k baud or 500k baud
- LIN: 9600 baud or 19200 baud

Initial Accuracy including Electronics

- CAN: $\pm 7^{\circ}\text{C}$ from -40°C to 1100°C
- PWM: $\pm 7^{\circ}\text{C}$ from -40°C to 1100°C
- LIN: $\pm 8^{\circ}\text{C}$ from -40°C to 1100°C
- Analog: $\pm 10^{\circ}\text{C}$ from -40°C to 499°C and 2% or $\pm 12.5^{\circ}\text{C}$, whichever is less, from 500°C to 1100°C

Response Time T63

- ~ 3 sec. In 70m/s moving air at 2.1 mm tip
- ~ 5 sec. In 20m/s moving air at 2.1 mm tip
- ~ 7 sec. In 70m/s moving air at 4.0 mm tip
- ~ 10.5 sec. In 20m/s moving air at 4.0 mm tip

Long Term Stability

- WATCOUPLE will drift $<0.2\%$ after exposure to 1000°C (1832°F) for a mean time of 40,000 hours with 90% confidence bounds.

Materials and Mounting

Sheath Materials

- 316 stainless steel, alloy 600 or Haynes® 230

Mounting Fittings

- M12x1.5-6g, M14x1.5-6g and M16x1.5-6g, 400 stainless steel

Lead Wire

- Available in lengths up to 12 feet
- 0.96 mm^2 (18 AWG - 19 strands of 30 AWG) stranded wire with Tefzel® insulation

Protective Sleeve

- 200°C (392°F) silicone coated fiberglass sleeve (optional)

Connector

- Tyco Electronics 776488-1 (AMPSEAL 16 SERIES) with 2 rows of 2 gold plated pins
- Mating connector: Tyco plug 776487-1, Tyco S&F gold plated socket 776492-1, Tyco plug seal 776363-1

Dimensional Drawings

Bent Probe (90°)

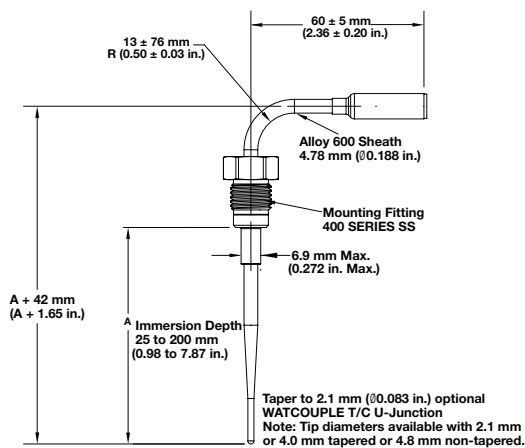

Straight Probe

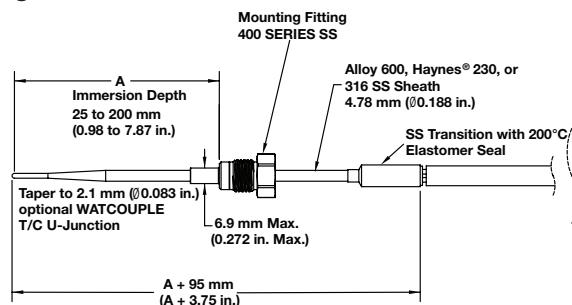

Output Specifications

CAN Output

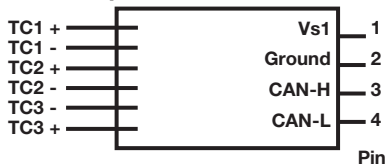

J1939 compatible output is available with up to three sensor tips.

PWM and Analog Outputs

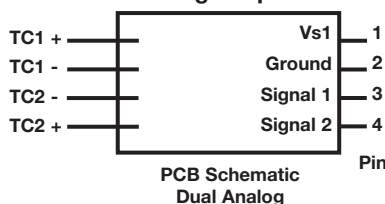

PWM and analog output are available with one or two sensor tips.

LIN Output

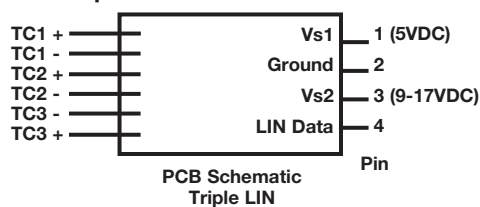

LIN output is available with up to three sensor tips.

To be automatically connected to the nearest North American Technical Sales Office:

1-800-WATLOW2 • www.watlow.com • inquiry@watlow.com

International Technical Sales Offices: Australia, +61 3 9335 6449 • China, +86 21 3532 8532 • France, +33 1 41 32 79 70
 Germany, +49 (0) 72 53 / 94 00-0 • Italy, +39 024588841 • Japan, +81 3 3518 6630 • Korea, +82 2 2628 5770
 Malaysia, +60 3 8076 8745 • Mexico, +52 442 217 6235 • Singapore, +65 6773 9488 • Spain, +34 91 675 12 92
 Taiwan, +886 7 288 5168 • United Kingdom, +44 (0) 115 964 0777