

CAS

User's Guide

Watlow Controls

1241 Bundy Blvd.
Winona, MN 55987

Customer Service

Phone: (800) 414-4299
Fax: (800) 445-8992

Technical Support

Phone: (507) 494-5656
Fax: (507) 452-4507
Email: wintechsupport@watlow.com

Part No. 21952-60. Revision 1.2
February 1996

Copyright © 1996
Watlow Anafaze

Information in this manual is subject to change without notice. No part of this publication may be reproduced, stored in a retrieval system, or transmitted in any form without written permission from Watlow Anafaze.

Warranty

Watlow Anafaze, Incorporated warrants that the products furnished under this Agreement will be free from defects in material and workmanship for a period of three years from the date of shipment. The customer shall provide notice of any defect to Watlow Anafaze within one week after the Customer's discovery of such defect. The sole obligation and liability of Watlow Anafaze under this warranty shall be to repair or replace, at its option and without cost to the Customer, the defective product or part.

Upon request by Watlow Anafaze, Incorporated, the product or part claimed to be defective shall immediately be returned at the Customer's expense to Watlow Anafaze. Replaced or repaired products or parts will be shipped to the Customer at the expense of Watlow Anafaze.

There shall be no warranty or liability for any products or parts that have been subject to misuse, accident, negligence, failure of electric power or modification by the Customer without the written approval of Watlow Anafaze. Final determination of warranty eligibility shall be made by Watlow Anafaze. If a warranty claim is considered invalid for any reason, the Customer will be charged for services performed and expenses incurred by Watlow Anafaze in handling and shipping the returned unit.

If replacement parts are supplied or repairs made during the original warranty period, the warranty period for the replacement or repaired part shall terminate with the termination of the warranty period of the original product or part.

The foregoing warranty constitutes the sole liability of Watlow Anafaze and the customer's sole remedy with respect to the products. It is in lieu of all other warranties, liabilities, and remedies. Except as thus provided, Watlow Anafaze disclaims all warranties, express or implied, including any warranty of merchantability or fitness for a particular purpose.

Please Note: External safety devices must be used with this equipment.

Contents

Introduction.....	1
CAS Features	3
Specifications.....	3
Analog Inputs.....	3
Digital Inputs	4
Digital Outputs.....	4
System Digital Outputs.....	4
Miscellaneous Specifications.....	5
Serial Interface	5
System Power Requirements	5
Environmental Specifications	5
Physical Dimensions.....	5
Installation.....	7
Precautions and Warnings	8
Recommended Tools	9
Panel Hole Cutters	9
Other Tools	9
CAS Mounting Procedure.....	10
Mounting Environment.....	10
TB-50 Mounting Instructions	11
General Wiring Recommendations.....	13
Grounding	14
Thermocouple Wiring.....	14
Input Wiring.....	15
Communications Wiring.....	15
Wiring: Noise Suppression	16
Symptoms of RFI.....	16
Avoiding Noise Problems.....	16
General Wiring	17
Power Wiring and System Test	17
Outputs.....	19
Wiring Outputs	19
Alarm Output Connections	21
Watchdog Timer	21
TB-50 Connections.....	22
Inputs	23
Input Scaling.....	23
Scaling Values	24

T/C Inputs	26
Current Inputs	26
Voltage Inputs	27
Unused Inputs	27
Back Terminal Block Connections	27
Serial Communications	28
RS-232 Interface	28
RS-485 Interface	28
Using the CAS	33
Introduction	33
Front Panel	34
Front Panel Keys	34
Single Channel Display	36
Job Display	37
Change Setpoint	38
Alarms	39
Setup	41
How to Enter the Setup Menus	41
How to Edit a Menu	41
CAS Menus	42
Setup Global Parameters Menu	43
Load a Job	43
Save Setup to Job	44
Job Select Inputs	44
Job Select Input Polarity	45
Startup Alarm Delay	45
Keyboard Lock Status	46
Scanner Address	46
Communications Error Checking	46
Communications Baud Rate	47
Allen-Bradley Protocol	47
AC Line Frequency	47
Digital Output Polarity	48
External Alarm Acknowledge Input	48
EPROM Information	48
Setup Channel Inputs	49
Input Type	49
Pulse Sample Time	50
Channel Name	50
Input Units	51
Input Reading Offset	51
Linear Scaling Menus	52

Display Format	54
High Process Value.....	54
Input Scaling High Reading.....	55
Input Scaling Low Process Value	55
Input Scaling Low Reading	56
Input Filter	56
Setup Channel Alarms	57
High Process Alarm Setpoint.....	59
High Process Alarm Type.....	59
High Process Alarm Output Number.....	60
Deviation Alarm Value.....	60
High Deviation Alarm Type	60
High Deviation Alarm Output Number	61
Low Deviation Alarm Type.....	61
Low Deviation Alarm Output Number	62
Low Process Alarm Setpoint	62
Low Process Alarm Type	62
Low Process Alarm Output Number	63
Alarm Deadband.....	63
Alarm Delay.....	64
Manual I/O Test	65
Digital Input Testing.....	65
Digital Output Selection	65
Digital Output Test	66
Keypad Test	66
Troubleshooting.....	67
Manual System Reset.....	68
Returning the Unit	68
Troubleshooting Stand-Alone Systems	69
Checking an Analog Input	69
Checking Digital I/O.....	69
Checking Computer Supervised Systems	71
Computer Problems	71
Software Problems.....	72
Changing the EPROM	73
Appendix: Linear Scaling Examples.....	75
Example 1	75
Example 2	76
Example 3	77
Glossary	79

Overview

This manual describes how to install, setup, and operate a CAS. Included are six chapters and a glossary of terms. Each chapter covers a different aspect of your control system and may apply to different users. The following describes the chapters and their purpose.

- **Introduction:** Gives a general description of the CAS and its related specifications.
- **Installation:** Describes how to install the CAS and its peripheral devices.
- **Using the CAS:** Provides an overview of operator displays used for system monitoring.
- **Setup:** Describes all the setup displays for the device, and how to access them.
- **Troubleshooting:** Gives some basic guidelines for solving operational problems.
- **Linear Scaling Examples:** Provides three examples where linear scaling is used.

System Diagram

The illustration below shows how the parts of the CAS are connected. When unpacking your system, use the diagram and parts list below to ensure all parts have been shipped. Please don't hesitate to call Watlow Anafaze's Technical Service Department if you have problems with your shipment, or if any CAS components are missing or damaged.

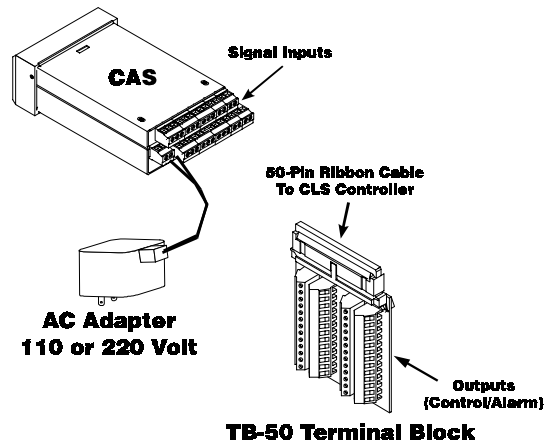

Parts List

- CAS Scanner
- Mounting Kit
- TB-50 Terminal Block
- 50-Pin Ribbon Cable
- AC Adapter (110V or 220V)

Safety

Watlow Anafaze has made efforts to ensure the reliability and safety of the CAS and to recommend safe uses in systems applications. Note that in any application failures can occur.

Good engineering practices, electrical codes, and insurance regulations require that you use independent external safety devices to prevent potentially dangerous or unsafe conditions. Assume that the CAS can fail or that other unexpected conditions can occur.

Install high or low temperature protection in systems where an overtemperature or undertemperature fault condition could present a fire hazard or other hazard. Failure to install temperature control protection where a potential hazard exists could result in damage to equipment and property, and injury to personnel.

For additional process safety, program a computer or other host device to automatically reload your desired operating parameters after a power failure. However, this safety feature does not eliminate the need for other external, independent safety devices in dangerous conditions.



WARNING

The CAS should never be used as a safety shutdown device. It should only be used with other approved independent safety shutdown devices.

Watlow Anafaze also offers ANASCAN®, an optional software program for IBM-compatible computers. In the event of a controller reset, ANASCAN will reload the CAS with the current values in computer memory. The user must ensure that this reset will be safe for the process. Again, use of ANASCAN does not eliminate the need for appropriate external, independent safety devices.

Contact Watlow Anafaze immediately if you have any questions about system safety or system operation.

Introduction

The CAS is a modular monitoring system with 16 fully independent inputs. It can function as a stand-alone system; the CAS 1/8 DIN front panel has a Liquid Crystal Display (LCD) and touch keypad for local display and local parameter entry. You can also use it as the key element in a computer supervised data acquisition system; the CAS can be locally or remotely controlled via an RS-232 or RS-485 serial communications interface.

Features include:

Direct Connection of Mixed Thermocouple Sensors: Directly connect most thermocouples with the CAS versatile hardware. Thermocouple inputs feature reference junction compensation, linearization, PV offset calibration to correct for sensor inaccuracies, T/C upscale break detection, and a choice of Fahrenheit or Celsius display.

Automatic Scaling for Linear Analog Inputs: The CAS automatically scales linear inputs used with other industrial process sensors. Simply enter two measurement points. For example, to scale a PSI sensor enter the endpoints: Low PV is 10 PSI, while High PV is 100 PSI. All other values for that channel will automatically be in PSI.

Flexible Alarm Outputs: Independently set high/low process alarms and a high/low deviation band alarm for each channel. Alarms can activate a digital output by themselves, or they can be grouped with other alarms to activate an output.

Alarm Outputs: You can set high/low deviation and high/low process alarm setpoints to operate digital outputs as latched or unlatched functions.

Global Alarm Output: When any alarm is triggered, the Global Alarm Output is also triggered, and it stays on until you acknowledge it.

Watchdog Timer: The CAS watchdog timer output notifies you of system failure. Use it to hold a relay closed while the system is running, so it notifies you of microprocessor failure.

Front Panel or Computer Operation: Set up and run the CAS from the front panel or from a local or remote computer. Watlow Anafaze offers ANASCAN, our IBM AT or IBM-PC compatible software you can use to operate the CAS. ANASCAN has these features:

- Process Overviews
- Parameter Setup
- Graphic Trend Plotting
- Data Logging

Multiple Job Storage: Store up to 8 jobs in protected memory, and access them locally by entering a single job number or remotely via digital inputs. Each job is a set of alarm conditions.

Pulse Counter Input Standard: Use the pulse counter input for precise monitoring of motor or belt speed.

Specifications

This section contains specifications for inputs, serial interface, system power requirements, environmental specifications, and physical dimensions.

Analog Inputs

Number of Analog Inputs: 16 single-ended/ common ground, plus one pulse input.

Input Switching: solid state MUX switching.

Input Sampling Rate: 1.5x/second (667 ms) at 60 Hz; 1.25x/second (300 ms) at 50 Hz.

Analog Over Voltage Protection: ± 20 V referenced to digital ground.

A/D Converter: Integrates voltage to frequency.

Input Range: -10 to +60 mV. Other ranges are available with scaling resistors.

Resolution: 0.006%, greater than 14 bits. (This is the internal measurement resolution, not the display resolution.)

Calibration: Automatic zero and full scale.

Thermocouple Ranges and Accuracy						
T/C Type	Range in °F	Range in °C	*Accuracy: 25°C Ambient		*Accuracy: 0 - 50° C Full Temp. Range	
			°C	°F	°C	°F
J T/C	-350 to 1400	-212 to 750	± 0.5	± 0.9	± 1.1	± 2.0
K T/C	-450 to 2500	-268 to 1371	± 0.6	± 1.2	± 1.35	± 2.7
T T/C	-450 to 750	-268 to 399	± 1.3	± 2.4	± 2.9	± 5.4
S T/C	0 to 3200	-18 to 1760	± 2.5	± 4.5	± 5.6	± 10.1
R T/C	0 to 3210	-18 to 1766	± 2.5	± 4.5	± 5.6	± 10.1
B T/C	150 to 3200	+66 to 1760	± 6.6	± 12.0	± 14.9	± 27.0
N T/C	-450 to 2370	-268 to 1299	± 1.0	± 1.8	± 2.25	± 4.1
PL-II T/C	+50 to 2012	+10 to 1100	± 0.6	± 1.0	± 1.2	± 2.2
* True for 10% to 100% of span.						

T/C Break Detection: Pulse type for upscale break detection.

Milliamp inputs: 0-20 mA (3 ohms resistance) or 0-10 mA (6 ohms resistance), with scaling resistors.

Voltage inputs: 0-12V, 0-10V, 0-5V, 0-1V, 0-500mV, 0-100 mV with scaling resistors.

Range	Input Resistance
0-12 V	85K ohms
0-10 V	50 K ohms
0-5 V	40 K ohms
0-1 V	7.4 K ohms
0-500mV	6.2 K ohms
0-100 mV	1.2 K ohms
0-20 mA	3 ohms
0-10 mA	6 ohms

Source Impedance: for 0-60 mV, measurements are within specification with up to 500 ohms source resistance.

Digital Inputs

Number: 8

Configuration: 8 selectable for remote job selection. Digital input #8 is only used for external alarm acknowledge.

Input Voltage Protection: Diodes to supply and common. The source must limit current to 10 mA for override conditions.

Voltage Levels: <1.3V=Low; >3.7V=High (TTL).

Maximum Switch Resistance to Pull Input Low: 1 Kohms.

Minimum Switch Off Resistance: 11 Kohms.

Digital Outputs

Number: 34

Operation: Open collector output; On state sinks to logic common. ≤ 20 mA for 35 outputs, ≤ 40 mA for a single output, I Total ≤ 700 mA.

Function: Selectable as alarm latched/unlatched.

Off State Leakage Current: <.01 mA to DC common.

System Digital Outputs

System Digital Outputs: 1 Global Alarm, 1 CPU watchdog.

Operation: Open collector output; On state sinks to logic common. ≤ 20 mA for 35 outputs, ≤ 40 mA for a single output, I Total ≤ 700 mA.

Miscellaneous Specifications

Serial Interface

Type: RS-232 3 wire or RS-485 4 wire.

Isolation:

RS-232 None

RS-485 To EIA RS-485 Specification.

Baud Rate: 2400 or 9600, user selectable.

Error Check: BCC or CRC, user selectable.

Number of Systems: 1 with RS-232 communications;
32 with RS-485 communications.

Protocol: Form of ANSI X3.28-1976.

System Power Requirements

Voltage: 12-24 Vdc

Input Current (no load): 300 mA max

Maximum Current Requirement: 610 mA. (If the reference voltage is externally loaded, add 1 mA supply current for every 1 mA of load up to a maximum load of 100 mA. If using the +5V logic supply to power digital outputs, add 0.6 mA supply current for every 1 mA of load up to a maximum load of 350 mA. Therefore, the maximum current requirement is $300 + 100 + (0.6 \times 350) = 610$ mA.)

Environmental Specifications

Storage Temperature: -20 to 60°C

Operating Temperature: 0 to 40°C

Humidity: 10 to 95% non-condensing.

Physical Dimensions

CAS: 1.75 lbs., 1.98" x 3.78" x 7.10" (.8 kg, 50 mm x 96 mm x 180 mm.)

TB-50: 3.2" x 3.4" (8.03 cm x 8.53 cm)

Installation

These installation instructions are written for non-technical users; if you are an electrician or you are technically proficient, they may seem simple to you.

This section explains installation for the CAS system only. If you are installing another Watlow Anafaze product, see the manual shipped with it to learn how to install it. This manual uses these symbols:



DANGER

This symbol warns you about hazards to human life.



WARNING

This symbol warns you of possible damage to property or equipment.



NOTE

This symbol denotes information you must know in order to proceed.

Precautions and Warnings



DANGER

Shut off power to your process before you install the CAS. High voltage may be present even when power is turned off! Reduce the danger of electric shock after installation, mount the CAS in an enclosure that prevents personal contact with electrical components.

The CAS measures input signals that are not normally referenced to ground, so the CAS inputs and other signal lines can have high voltage present even when power is turned off. For example, if you inadvertently short a thermocouple to the AC power line.



WARNING

During installation and wiring, place temporary covers over the housing slots and the rear of the CAS so dirt, pieces of wire, et cetera don't fall through the slots. Remove these covers after installation.

Install the CAS so the housing slots receive unrestricted airflow after installation. Make sure that other equipment does not block airflow to the slots.

Use #20 or #22 AWG wires and trim wire insulation to ¼" or 5 mm. Wire should fit inside the terminal with no bare wire exposed, to prevent contact between wires and the grounded case. Tin any stranded wire.

Support power, input and output wires to reduce strain on the terminals and to prevent wire removal.



NOTE

Choose a panel location that leaves enough clearance to install and remove the CAS and its components.

Recommended Tools

Use these tools to install the CAS:

Panel Hole Cutters

Use any of the following tools to cut a hole of the appropriate size in the panel.

- Jigsaw and metal file-for stainless steel and heavyweight panel doors.
- Greenlee 1/8 DIN rectangular punch (Greenlee part # 600-68), for most panel materials and thicknesses.
- Nibbler and metal file-for aluminum and other lightweight panel doors.

Other Tools

Use these tools to wire the CAS after you have installed it.

- Phillips head screwdriver.
- Flathead screwdriver for wiring.
- Multimeter.

CAS Mounting Procedure



NOTE

Mount the monitor before you mount the TB-50 or do any wiring. The monitor's placement affects placement and wiring for other components in your system.

Mounting Environment

Install the CAS in a location free from excessive ($>40\text{ }^{\circ}\text{C}$) heat, dust, and unauthorized handling. The monitor can mount in any panel material up to 0.2" thick. (Make sure there is enough clearance for mounting brackets and terminal blocks; the monitor extends 6.2" behind the panel face and the screw brackets extend 0.5" above and below it.)

Steps:

1. Cut a hole 3.630 ± 0.020 " long by 1.800 ± 0.020 " tall in the panel. This figure shows the mounting hole. Cut carefully; the 0.020" (0.5 mm) tolerances don't allow much room for error. Use a punch, nibbler, or jigsaw, and file the edges of the hole.

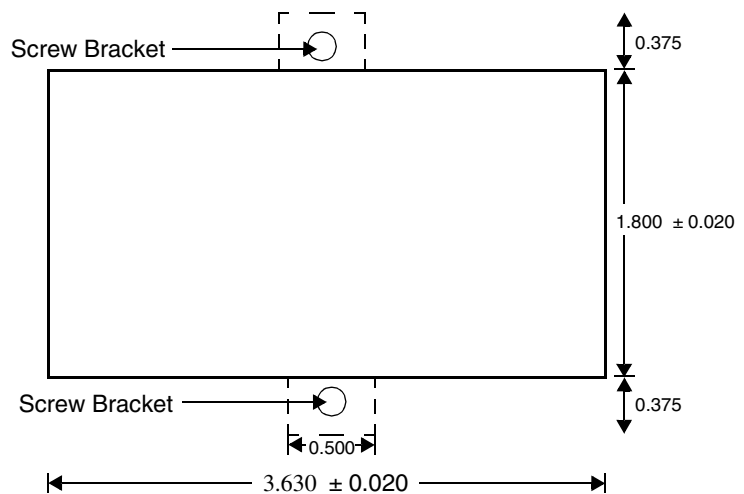

2. Insert the CAS into the hole through the front of the panel.
3. Screw the top and bottom clips in place: insert the screw's lip into the cutout in the metal housing just behind the front panel. Tighten the screw.
4. If you expect much panel vibration, use a rear support for the CAS and its interconnecting cables.

TB-50 Mounting Instructions

To connect alarms to the CAS System, wire them to the TB-50 (50-pin terminal block). These steps tell you how to mount it on any flat surface. (Please follow this procedure exactly, so you do not damage the terminal block, ribbon cable, or monitor.)

1. Choose a mounting location. Be sure there is enough clearance to install and remove the TB-50; it measures 3.4" long x 3.2" wide x 1.27" tall.
2. Watlow Anafaze shipped the TB-50 to you in an antistatic bag. Make sure these parts are also in the bag:
 - Five plastic standoffs.
 - Five 6-32 screws.
 - Five cable tie wraps.
 - One 50-pin ribbon cable.
 - Five ribbon cable clamps.
3. Snap four of the plastic standoffs into the four mounting holes on the TB-50.

There are also four smaller holes on the terminal board, as shown here. These holes are for the cable tie wraps—the plastic standoffs won't fit them. You'll use these holes to secure wiring to the terminal block. (See *Wiring Outputs* in this chapter for help installing cable tie wraps.)

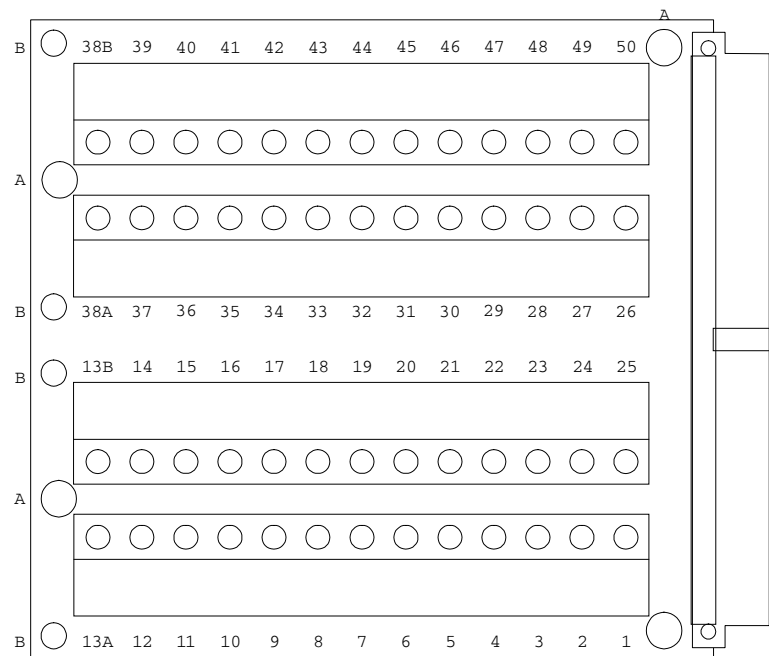

Holes labeled "A" are mounting holes.
Holes labeled "B" are tie wrap holes.

1. Place the TB-50 where you will mount it and use a pencil to trace around the standoffs.
2. Drill and tap #6-32 holes in the locations you marked.
3. Place the TB-50 where you will mount it. Insert the #6 screws in the standoffs and tighten them.



NOTE

Save the cable tie wraps, ribbon cable, and ribbon cable clamps. You'll use them when you wire outputs to the TB-50 and when you connect the ribbon cable.



WARNING

Do not connect power to the CAS now. Test the unit first, as explained in the Power Wiring and System Test section.

General Wiring Recommendations

Use the cables below or their equivalent. For best results, use appropriate materials, proper installation techniques and the correct equipment. For example, choose wire type by function, installation requirements, and the likelihood of mechanical or electrical problems at your installation.

Function	MFR P/N	No. of Wires	AWG
Analog inputs	Belden #9154	2	20
	Belden #8451	2	22
Thermocouple inputs	Thermocouple extension wire	2	20
Digital I/O	Belden #9539	9	24
	Belden #9542	20	24
	Ribbon Cable	50	
Computer Communication: RS-232 or RS-485	Belden #9729	4	24
	Belden #9730	6	24
	Belden #9842	4	24
	Belden #9843	6	24



WARNING

Never wire bundles of low power Watlow Anafaze circuits next to bundles of high power AC wiring. Always physically separate high power circuits from the monitor. If possible, install high voltage AC power circuits in a separate panel.

- Use stranded wire. (Use solid wire for fixed service only).
- Use #18 or #20 AWG wire. Larger or smaller sizes may be difficult to install, may break easily, or may cause intermittent connections.
- Use shielded wire. (The electrical shield helps protect the CAS from electrical noise.) Connect one end of the input wiring shield to the CAS panel's 120 Vac panel ground, and connect one end of the output wiring shield to the CAS panel's 120 Vac panel ground. If these instructions do not apply to your system, contact Watlow Anafaze for more information.

For additional noise suppression measures, see *Noise Suppression*.

Grounding

Connect the CAS power supply common to an external ground at only one point, to avoid ground loops that can cause instrument errors or malfunctions. Since the CAS uses a non-isolated measurement system, it has the following connections to power supply common:

- Analog Common TB1 pins 5, 6, 11, & 12.
- Reference Common, TB1 pin 17.
- Communications ground (TB1 pins 23 & 24) if using RS-232.
- Power Supply Ground, TB2 pin 2.

Watlow Anafaze strongly recommends that you:

- Do not connect to earth ground unless recommended by the factory for a specific application.
- Isolate outputs through solid state relays, where possible.
- Isolate digital inputs from ground through solid state relays. If you can't do that, then make sure the digital input is the only place that one of the above pins connects to ground.
- If you are using RS-232 from an un-isolated host, don't connect any other power common point to earth ground.

Thermocouple Wiring

Use 18 or 20 AWG thermocouple (T/C) extension wire for all T/C inputs.



NOTE

Most thermocouple wire is solid unshielded wire. Use shielded wire if required at your installation; ground one end only.

Since the CAS has single ended inputs, it has little protection from common mode voltage sources. Therefore, Watlow Anafaze highly recommends that you use ungrounded thermocouples with the external thermocouple sheath electrically connected to earth ground.

You can use 400 to 500 feet of thermocouple extension wire, depending on wire type and size, and keep to accuracy and source impedance specifications. Always install T/C wiring in a separate conduit away from AC power (the 120 VAC control supply) and high power (240 VAC or higher) wiring.

Input Wiring

Use multicolor stranded shielded cable for analog inputs. We recommend that you use #20 AWG wire. (If the sensor manufacturer requires it, you can also use #22 or #24 AWG wiring.) Most inputs use a shielded twisted pair; some require a 3 wire input.

Communications Wiring

Large systems can pull an extra pair of wires to the computer communications wiring. The extra pair services a sound power phone system for communications between the CAS and a computer. If you choose this option for maintenance, calibration checking, Watlow Anafaze recommends a David Clark #H5030 system.

Wiring: Noise Suppression

If the outputs control dry contact electromechanical relays with inductive loads, like alarm horns, you may get Radio-Frequency Interference (RFI, or "noise"). This section explains how to avoid noise problems; read it before you wire the CAS.

Symptoms of RFI

- If your system displays the following symptoms, suspect RFI.
- The CAS display blanks out and then reenergizes as if power had been turned off for a moment.
- The process value does not display correctly.

RFI may also damage the digital output circuit, so digital outputs will not energize. If the digital output circuit is damaged, return the system to Watlow Anafaze for repair.

Avoiding Noise Problems

Use these techniques to avoid noise problems.

Where possible, use solid state relays (SSRs) instead of electromechanical (EM) relays. If you must use EM relays, try to avoid mounting them in the same panel as Watlow Anafaze equipment.

Separate the 120 Vac power leads from the low level input and output leads connected to the CAS. Don't run the digital output or PID control output leads in bundles with 120 Vac wires. (Never run input leads in bundles with high power leads— see the General Wiring section.)

If you must use EM relays and you must place them in a panel with Watlow Anafaze equipment, use a .01 mF capacitor rated at 1000 Vac (or higher) in series with a 47 ohm, ½ watt resistor across the normally open (NO) contacts of the relay load. This network is known as an arc suppressor or snubber network.

You can use other voltage suppression devices, but they are not usually required. For instance, you can place a metal oxide varistor (MOV) rated at 130 Vac for 120 Vac control circuits across the load, which limits the peak AC voltage to about 180 Vac. You can also place a transorb (back to back zener diodes) across the digital output, which limits the digital output loop to 5 Vdc. (These parts are available from Watlow Anafaze.)

These steps will eliminate most noise problems. If you have further problems or questions, please contact Watlow Anafaze.

General Wiring

This section explains how to test your installation before you connect power to it and how to connect inputs and outputs to it.

Power Wiring and System Test

When you have installed the system and the TB-50, use this checklist to connect them. (These instructions are written so that non-electricians can understand them. If you are an experienced electrician, they may seem elementary to you. If so, feel free to skim them.)

Connecting Power and TB-50 to CAS

1. Remove the temporary covers on the CAS housing.
2. Connect the power supply. Do not turn on the AC power yet.
3. Connect the ribbon cable to the system, as shown here. Plug it in so the red stripe is on the left side as you face the back of the system.

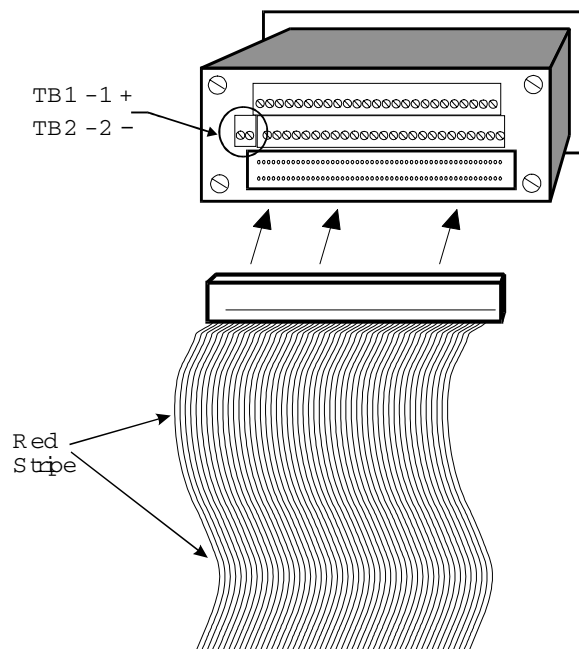

4. Connect the ribbon cable to the TB-50. The cable is keyed, so you cannot insert it backwards.



WARNING

Do not turn on AC power yet. First test the connections, as explained in the Connections Test section (below).

Excessive voltage to the CAS will damage it, and you will need to return it to Watlow Anafaze for repair. If you are not using the Watlow Anafaze power supply, read the next section completely and follow its instructions before you apply power.

Connections Test

1. Unscrew the four screws on the sides of the front panel.
2. Gently slide the electronics assembly out of the case.
You have now removed the parts of the CAS which will be damaged by excess voltage, so plug in the transformer power supply and use a voltmeter to check voltages:
3. Touch the meter Common lead to Back Terminal Block 2 (TB2) terminal 2 on the CAS. The voltage on TB2 terminal 1 should then be +12 to 24 Vdc (no load).
4. If the voltages are within the limits described above,
 - A. Turn off power.
 - B. Slide the electronics assembly back into the processor module's casing.
 - C. Reinsert screws into the screw holes on the casing and tighten them.
 - D. Turn the power back on. The display should light up, and after about a second the single channel display should appear.
5. If you have not connected analog inputs yet, the CAS may display a "T/C Break" alarm message for each channel. This is normal; to clear the alarm messages, press ALARM ACK once for each alarm message.

Outputs



NOTE

All digital outputs are sink outputs referenced to the 5Vdc supply. These outputs are low (pulled to common) when they are ON.

All digital inputs are Transistor-Transistor Logic (TTL) level inputs referenced to control common.

The alarm outputs are located on the 50-pin header which connects to the 50-pin flat ribbon cable. This section explains how to wire and configure alarm outputs.

Wiring Outputs

The digital outputs sink current from a load connected to the CAS' internal power supply, or from an external power supply referenced to CAS ground.

- If you use an external power supply, do not exceed +12 volts.
- If you tie the external load to ground, or if you cannot connect it as shown below, then use a solid state relay.
- If you connect an external supply to earth or equipment ground, use solid state relays to avoid ground currents. (Ground currents may degrade analog measurements in the CAS).

The outputs conduct current when they are "True". The maximum current sink capability is 20 mA (for all outputs, refer to spec. for details). They cannot "source" current to a ground load.

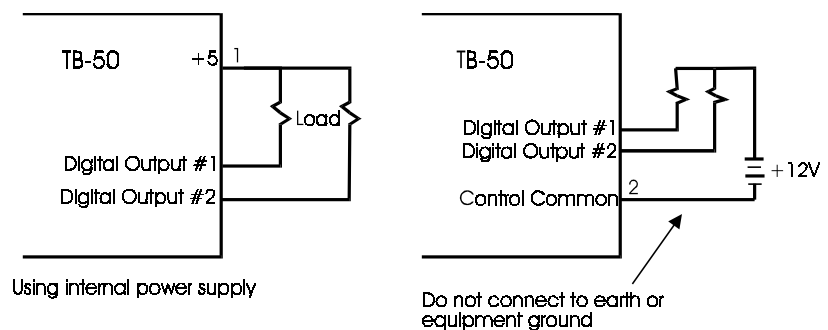

Using the Cable Tie Wraps

When you have wired outputs to the TB-50, use the cable tie wraps shipped with it. This diagram shows the cable tie wrap holes.

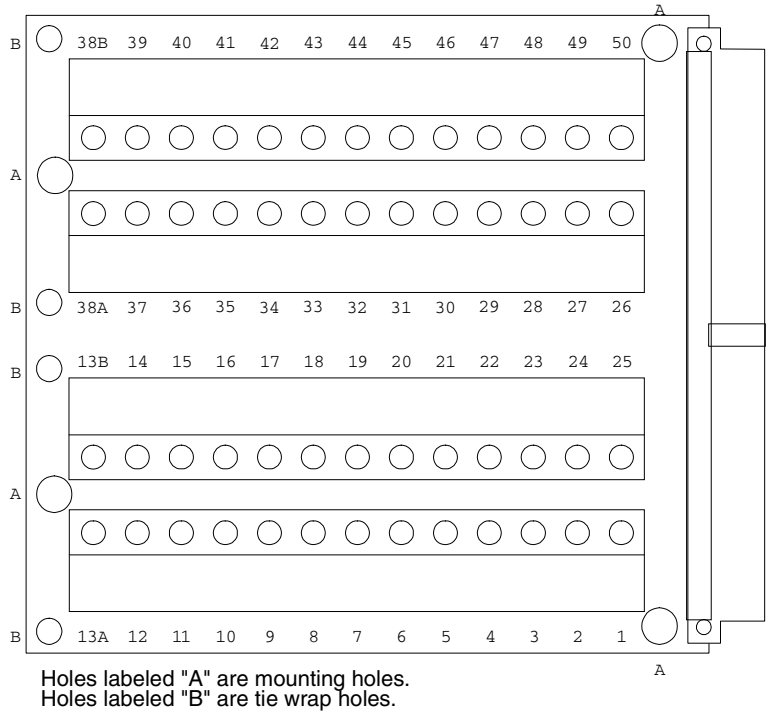

Each row of terminals has a cable tie wrap hole at one end. Thread the cable tie wrap through the cable tie wrap hole. Then wrap the cable tie around the wires attached to that terminal block.

Alarm Output Connections

Typical digital outputs use external optically isolated solid-state relays (SSRs). The SSRs use a 3 to 32 Vdc input for control, and you can size them to switch up to 100 amps at 480 Vac. For larger currents, you can use optically isolated relays to drive contactors.



NOTE

Digital outputs are SINK outputs. They are Low when the output is On. Connect them to the negative side of Solid State Relays.

The figure below shows sample alarm output connections.

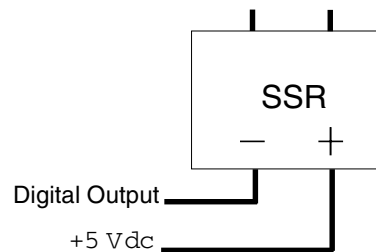

Watchdog Timer

The CAS watchdog timer monitors the CAS microprocessor. It is a sink output located on TB-50 terminal #6. (Do not exceed the rating for the watchdog timer.) Its output is Low (on) when the microprocessor is operating; when it stops operating, the output goes High (off), which de-energizes the SSR.

Here's the recommended circuit for the watchdog timer output:

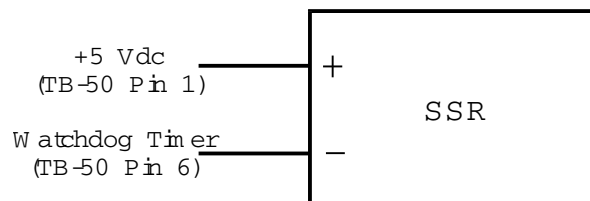

TB-50 Connections

This table shows TB-50 connections.

Pin	Function	Pin	Function
1	+5 Vdc	2	+5 Vdc
3	Digital Ground	4	Digital Ground
5	Not Used	6	Watchdog Timer
7	Pulse input	8	Global Alarm
9	DIG output 1	10	DIG output 34
11	DIG output 2	12	DIG output 33
13	DIG output 3	14	DIG output 32
15	DIG output 4	16	DIG output 31
17	DIG output 5	18	DIG output 30
19	DIG output 6	20	DIG output 29
21	DIG output 7	22	DIG output 28
23	DIG output 8	24	DIG output 27
25	DIG output 9	26	DIG output 26
27	DIG output 10	28	DIG output 25
29	DIG output 11	30	DIG output 24
31	DIG output 12	32	DIG output 23
33	DIG output 13	34	DIG output 22
35	DIG output 14	36	DIG output 21
37	DIG output 15	38	DIG output 20
39	DIG output 16	40	DIG output 19
41	DIG output 17	42	DIG output 18
43	DIG input 1	44	DIG input 2
45	DIG input 3	46	DIG input 4
47	DIG input 5	48	DIG input 6
49	DIG input 7	50	DIG input 8

Inputs

This section covers input scaling and input installation for all input types, including thermocouples, current inputs, and voltage inputs.

Input Scaling

The analog input circuitry in the CAS accepts any mix of thermocouples, current inputs, and voltage inputs. You can directly connect the following inputs:

- J, K, T, S, R, B, PL-II, and N type thermocouples.
- Linear inputs with ranges between -10 and 60 mV.

Other inputs require custom scaling resistors. If you didn't order your unit with the appropriate resistors, you have these options:

- Watlow Anafaze can install scaling resistors on your unit for a small fee.
- Watlow Anafaze can supply a scaling resistor kit that a qualified technician can use to install scaling resistors.



WARNING

A qualified technician can install scaling resistors in the CAS. However, damage to the CAS due to improper resistor installation is not covered under warranty, and repairs can be expensive. If you have any doubts about your ability to install scaling resistors, send your CAS to Watlow Anafaze for resistor installation.

Scaling Values

For linear mVdc, Vdc, and mA dc ranges, use 0.1% tolerance resistors. Larger tolerances may cause significant errors. Correct any errors due to resistor tolerance with built-in linear scaling. You can also install other components (like capacitors) for signal conditioning; please consult Watlow Anafaze for more information.

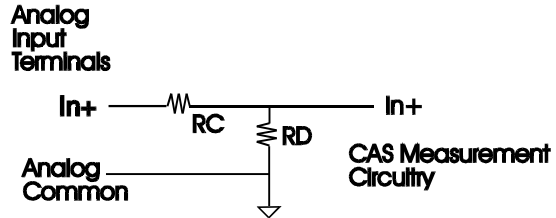

The next table shows scaling resistor values.

Input Range	RC	RD
All T/C, 0-60 mV DC	Jumper	
0-10 mA DC	Jumper	6.0 ohms
0-20 mA DC	Jumper	3.0 ohms
0-100 mV	499 ohms	750 ohms
0-500 mV	5.49 Kohms	750 ohms
0-1 VDC	6.91 Kohms	422.0 ohms
0-5 VDC	39.2 Kohms	475.0 ohms
0-10 VDC	49.9 Kohms	301.0 ohms
0-12 VDC	84.5 Kohms	422.0 ohms

The next table shows the location of RC and RD on the analog input board. (The analog input board is the upper board of the two-board set.)

Channel #	RC	RD
1	R58	R42
2	R56	R40
3	R54	R38
4	R52	R36
5	R50	R34
6	R48	R32
7	R46	R30
8	R44	R28
9	R57	R41
10	R55	R39
11	R53	R37
12	R51	R35
13	R49	R33
14	R47	R31
15	R45	R29
16	R43	R27

A wire trace on the printed circuit board jumpers the RC position. When you place a resistor in the RC position, cut the wire trace that connects the two resistor terminals.

Scaling and Calibration

The CAS provides offset calibration for thermocouples and other fixed ranges, and offset and span (gain) calibration for linear and pulse inputs. (Offset and span calibration convert linear analog inputs into engineering units using the $Mx+B$ function.)

In order to scale linear input signals, you must:

1. Install appropriate scaling resistors.
2. Select the display format. The smallest possible range is $-.9999$ to $+3.0000$; the largest possible range is -9999 to 30000 .
3. Enter the appropriate scaling values for your process.

For more information about input scaling and input offset, see Setup Channel Inputs in Chapter 4: Setup.

T/C Inputs



WARNING

Since the CAS has single ended inputs, it has little protection from common mode voltage sources. Therefore Watlow Anafaze highly recommends that you use ungrounded thermocouples with the EXTERNAL THERMOCOUPLE SHEATH ELECTRICALLY CONNECTED TO EARTH GROUND.

You can connect J, K, T, S, R, B, PL-II, and N thermocouples directly to the CAS. Watlow Anafaze provides standard linearization and cold junction compensation for these thermocouple types. Other thermocouple types require custom linearization; please contact Watlow Anafaze for more information about them.

Connecting Thermocouples

Connect the positive T/C lead to the In+ terminal. Connect the negative T/C lead to the TB1 analog common terminal on the CAS. The next figure shows a typical thermocouple connection.

- Use 20 gauge T/C extension wire for all T/C inputs.
- If you use shielded wire, **tie it to panel ground or to ground at the measurement end**

Back Terminal Block Connections

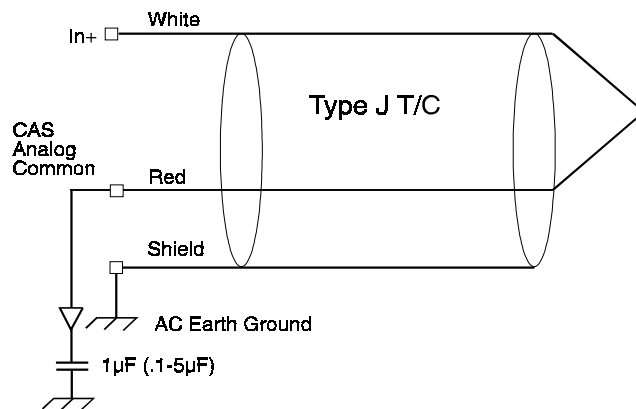

Current Inputs

To connect current (milliamp) inputs, install resistors that convert the milliamp input to a voltage. Watlow Anafaze offers resistors for 0-20 mA and 0-10 mA current inputs.

Voltage Inputs

- Connect the + side of the voltage input to the In+ terminal.
- Connect the - side of the input to analog common. The voltage input range is -10 to 60 mV.
- Scale signals larger than 60 mV with scaling resistors that make full scale input 60 mV. (For more information about scaling resistors, request Watlow Anafaze's technical note, Installing Scaling Resistors in the CAS.)

The figure below shows a typical voltage input.

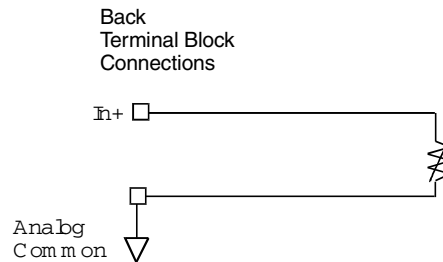

Unused Inputs

Set the input type for unused inputs to "SKIP" to avoid the default T/C break alarms. (See Input Type in Chapter 4: Setup for information on setting the input type.)

Back Terminal Block Connections

Wire inputs to the back terminal block as shown here.

TB1	1	3	5	7	9	11	13	15	17	19	21	23	25		
	CH 1 IN+	CH 2 IN+	Ana- log Com	CH 3 IN+	CH 4 IN+	Ana- log Com	CH 5 IN+	CH 6 IN+	Ref. Gnd	CH 7 IN+	CH 8 IN+	GND / RXB	RX / RXA		
TB2	1	2	2	4	6	8	10	12	14	16	18	20	22	24	26
	+V pwr	Pwr Com	CH 9 IN+	CH 10 IN+	Ana- log Com	CH 11 IN+	CH 12 IN+	Ana- log Com	CH 13 IN+	CH 14 IN+	+5V Ref.	CH 15 IN+	CH 16 IN+	GND / TXB	TX / TXA

Serial Communications

The CAS is factory-configured for RS-232 communications. However, the communications are jumper-selectable, so you can switch between RS-232 and RS-485. (See Configuring Communications below.) You can also order a communications cable from Watlow Anafaze or make your own cable.

RS-232 Interface

With RS-232 communications, you can connect the CAS System directly to the serial communications connector on an IBM-PC or compatible computer. (PC-compatible computers typically use RS-232 communications.) The RS-232 interface is a standard three-wire interface. (See the table below for connection information. Some computers reverse transmit (TX) and receive (RX), so check your computer manual to verify your connections.)

You can use RS-232 or RS-485 communications in these situations:

- When you are using local communications (up to 50 feet).
- When you are using a single CAS system.

If you use RS-232 communications with grounded thermocouples, use an optical isolator between the system and the computer.

This table shows RS-232 connections for 25-pin and 9-pin connectors.

DB 25 Connector	DB 9 Connector	CAS Back TB	Anafaze Cable
RX Pin 3	RX Pin 2	TX Pin 26	White
TX Pin 2	TX Pin 3	RX Pin 25	Red
GND Pin 7	GND Pin 5	GND Pin 23	Black

RS-485 Interface

- If you use more than one CAS System, you must use RS-485 communications.
- If you have connected the CAS System to a computer more than 50 feet away, Watlow Anafaze recommends that you use RS-485 communications.

If you use RS-485 communications, attach an optically isolated RS-232 to RS-485 converter to the computer. You can use an internal converter card or an external plug-in converter.

The diagram below shows the recommended system hookup. To avoid ground loops, it uses an optically isolated RS-232 to RS-485 converter at the host computer. It is powered from the CAS System's power source or from a secure, isolated power supply.

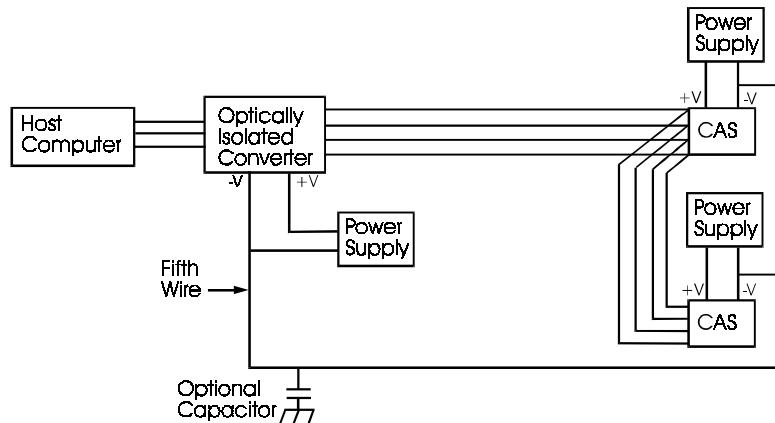

Wire equipment in a single "daisy chain" using twisted shielded pairs for the RS-485 cables. Don't use "octopus connections" or "spurs".

Use a 200 ohm terminating resistor on the RX line of the last system in the system. (If you have only one system, it is the last system in the system.) Use jumper JU1 to select the terminating resistor; place it in B position for termination and A position for non-termination.

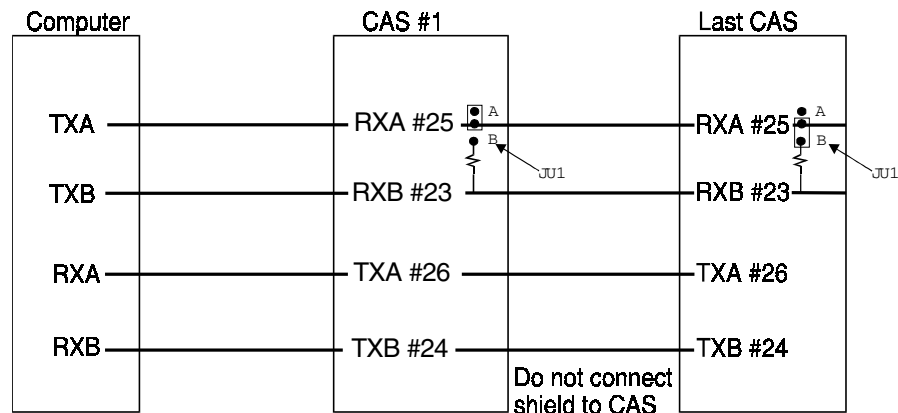

NOTE

Connect the shields to earth ground only at the computer or other 485 interface. Do not connect the shield to the CAS. If the RS-485 communications do not function properly, or if you have measurement problems when communications lines are connected, contact Watlow Anafaze Technical Service Department.

Configuring Communications

Your system is shipped configured for RS-232. To switch between RS-232 and RS-485, change the jumpers as shown here.

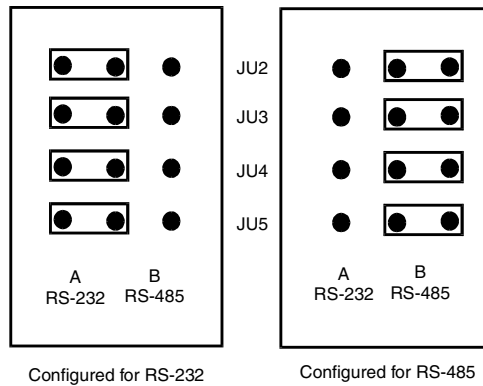

You'll need a Phillips head screwdriver and tweezers to switch between RS-232 and RS-485. Follow these steps:

1. Power down the unit.
2. Remove the system's metal casing. Refer to the section *Changing the Prom* in the Troubleshooting chapter of this manual.
3. Find jumpers JU2, JU3, JU4, and JU5 (above).
4. (This part of the explanation assumes that you're changing the communications from RS-232 to RS-485. If you're not, follow the next two steps but move the jumpers from the B position to the A position.) Use tweezers to carefully grasp the jumpers and gently slide them off the pins.
5. Use tweezers to gently slide the jumpers onto the B pins. Move jumpers JU2, JU3, JU4, and JU5 to the B position, as shown above.
6. If you have changed the system to 485 communications, put the 200 ohm terminating resistor on the RX line of the last monitor in the system. (If you're only using one monitor, it's the last monitor in the system.) Place jumper JU1 in the B position. All other monitors in the system should have JU1 in the A position.
7. Put the casing back on.

Recommended Wire Gauges

Watlow Anafaze recommends the following maximum distances and wire gauges:

Distance	Wire Gauge	Recommended Cable
4000 ft.	24 AWG	Belden #9729 Belden #9842
6000 ft.	22 AWG	Belden #9184

You may wish to use a shield, depending on your noise environment and grounding problems. The above cables are shielded.



NOTE

These recommendations are conservative, to ensure that the CAS will operate reliably. Expect satisfactory performance even if you must deviate slightly from a design specification.

Using the CAS

Introduction

This chapter will show you how to use the CAS from the front panel. (If you are using ANASCAN, please see the ANASCAN User's Guide.) The next diagram shows how to reach the operator menus from Single Channel display. (To change global parameters, channel inputs, and alarms from the setup menus, you must enter a special sequence of keys. To learn how, see *Setup*.)

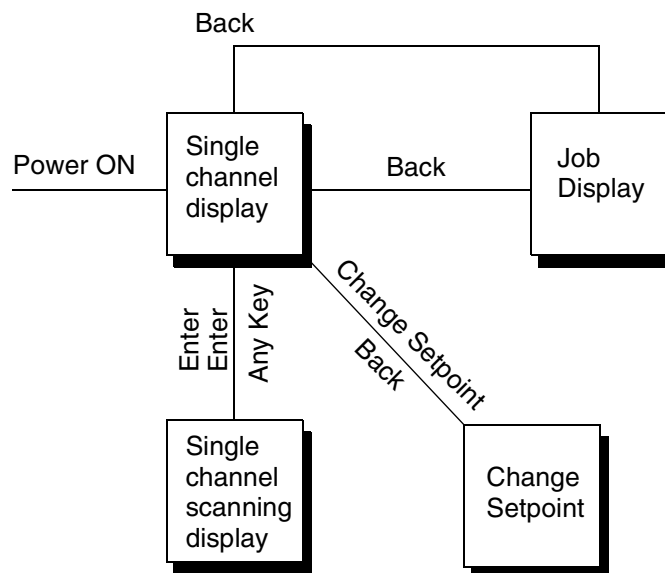

Front Panel

The front panel provides a convenient interface with the CAS system. You can program and operate the CAS with the front panel keys shown below, or you can use ANASCAN, a program designed specifically for the CAS.

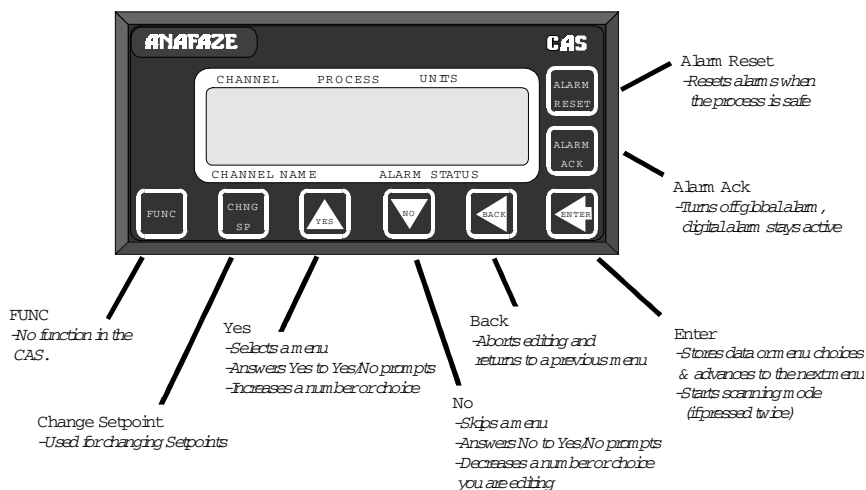

Front Panel Keys



Yes

Press Yes to:

- Select a menu.
- Answer Yes to Yes/No questions.
- Increase a number or choice you're editing.



No

Press No to:

- Skip a menu you don't want to edit, when the prompt is blinking.
- Answer No to Yes/No prompts.
- Decrease a number or choice when editing.
- Perform a Manual System Reset on power-up.



WARNING

A Manual System Reset clears the system's memory and reinitializes the CAS factory defaults. To do a Manual System Reset, power down the CAS, press and hold the No key during power-up. This is required during installation, after changing the EPROM, or when troubleshooting.



Back

The Back key works like an "escape" key. Press it to:

- Abort editing.
- Return to a previous menu.
- Switch between single channel and job control displays.



Enter

Press the Enter key to:

- Store data or menu choices after editing and go to the next menu.
- Start scanning mode (if pressed twice).



Alarm Ack

Press Alarm Ack to:

- Acknowledge an alarm condition and reset the global alarm.
- Stops the scanning display



Alarm Reset

Press Alarm Reset to:

- Will clear an alarm when the process is in a non-alarming state.
- Will operate the same as the Alarm Ack key if the process is in an alarming state.



Change SP

Press Change SP to change the setpoints.



Func

The FUNC key is not used in normal operation. It is reserved for future enhancement.

Single Channel Display

Single Channel display (below) shows detailed information for one channel.

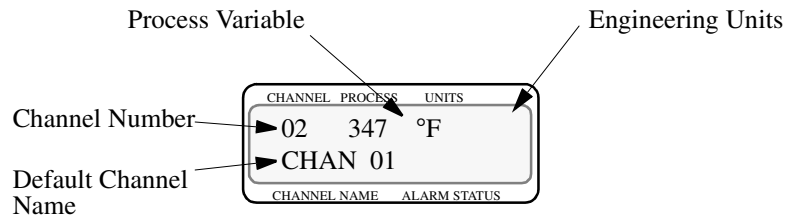

From Single Channel Display,

- Press Yes to go to the next channel.
- Press No to go to the previous channel.
- Press the Back key once to go to Job display (if it is enabled).
- Press Enter twice to start Single Channel Scanning display. (The Single Channel Scanning Display shows information for each channel for one second.)
- Press any key to stop scanning mode.

Job Display

Job display appears only if:

- You have turned on the Remote Job Select function. (This function is explained in Chapter 4: Setup.)
- You have selected a job from the job load menu.

When you load a job, Job display shows you this screen:

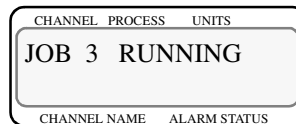

If you remotely loaded the job, Job display looks like this:

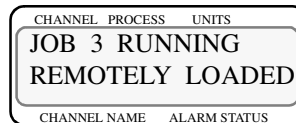

If you modify a job's parameters while the job is running, you'll see this message:



If an alarm occurs, the controller switches to Single Channel Display.

Change Setpoint

To change the setpoint, go to the Single Channel Display of the channel you want to change, and press the **Change Setpoint** key (the setpoint is the desired temperature, pH, et cetera, for the process). You should see a display like this:

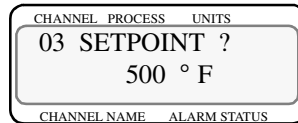

- Press **Yes** to change the setpoint.
- Then press **Yes** or **No** to change the setpoint value.
- When you are satisfied with the setpoint value you have chosen, press **Enter** to save your changes and return to Single Channel Display; or
- To return to Single Channel Display without saving your changes, press **No** or **Back**.

Alarms

If an alarm occurs, an eight character alarm code is displayed in the lower-right section of the display. If a Failed Sensor alarm occurs, the controller also displays this short alarm message:

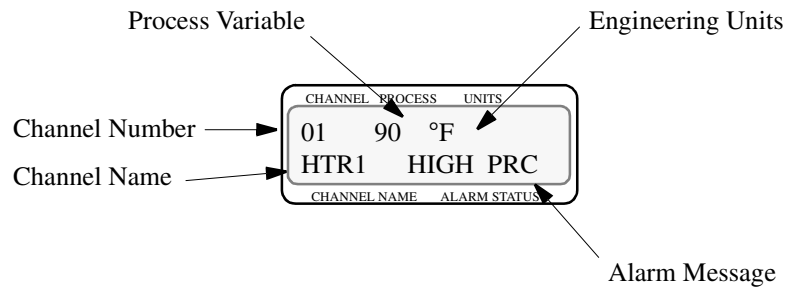

These alarm codes and messages are shown in the table below.

Alarm Message	Alarm Type
TC BREAK	Thermocouple Break
HIGH PRC	High process alarm
HIGH DEV	High deviation alarm
LOW DEV	Low deviation alarm
LOW PRC	Low process alarm

Acknowledging an Alarm

Press the Alarm Acknowledge key to acknowledge an alarm. If there are other channels with alarm conditions, the Alarm display switches to the next channel in alarm. Acknowledge all alarms to clear the global alarm.

The Alarm Acknowledge key operates differently in latched and unlatched modes. In latched mode, an alarm can only be cleared when the process is in a non-alarming state, and the Alarm Reset key is pressed. In un-latched mode, the alarm clears automatically when the Alarm Acknowledge key is pressed and the system is in a non-alarming state.

Resetting an Alarm

Pressing the Alarm Reset key clears an alarm only if the system is in a non-alarming state. Otherwise, the key will operate the same as the Alarm Acknowledge key.

Setup

The Setup menus let you change detailed configuration information.

How to Enter the Setup Menus

1. In Single Channel Display, select the channel you wish to edit.
2. While still in Single Channel Display, enter the pass sequence below: Press **Enter**, **Alarm Ack**, **Change Setpoint**.



3. The first setup menu appears.



NOTE

If you are in the Setup menus and you don't make any changes for three minutes, the CAS reverts to Single Channel Display for your protection.

How to Edit a Menu

- Press **Yes** to select the menu or **No** to advance to the next menu.
- Press **Yes** or **No** to toggle between the option in your menu.
- Press **Enter** to store the value you have selected.
- If you decide not to edit the menu, press **Back** to stop editing and return to the main menu.

Each display contains the default value for that specific menu, and below each display, you will see the range of choices for that menu.

The following sections tell more about the submenus for each of the four main menus. The next page shows the setup menus accessible from Single Channel Display.

CAS Menus

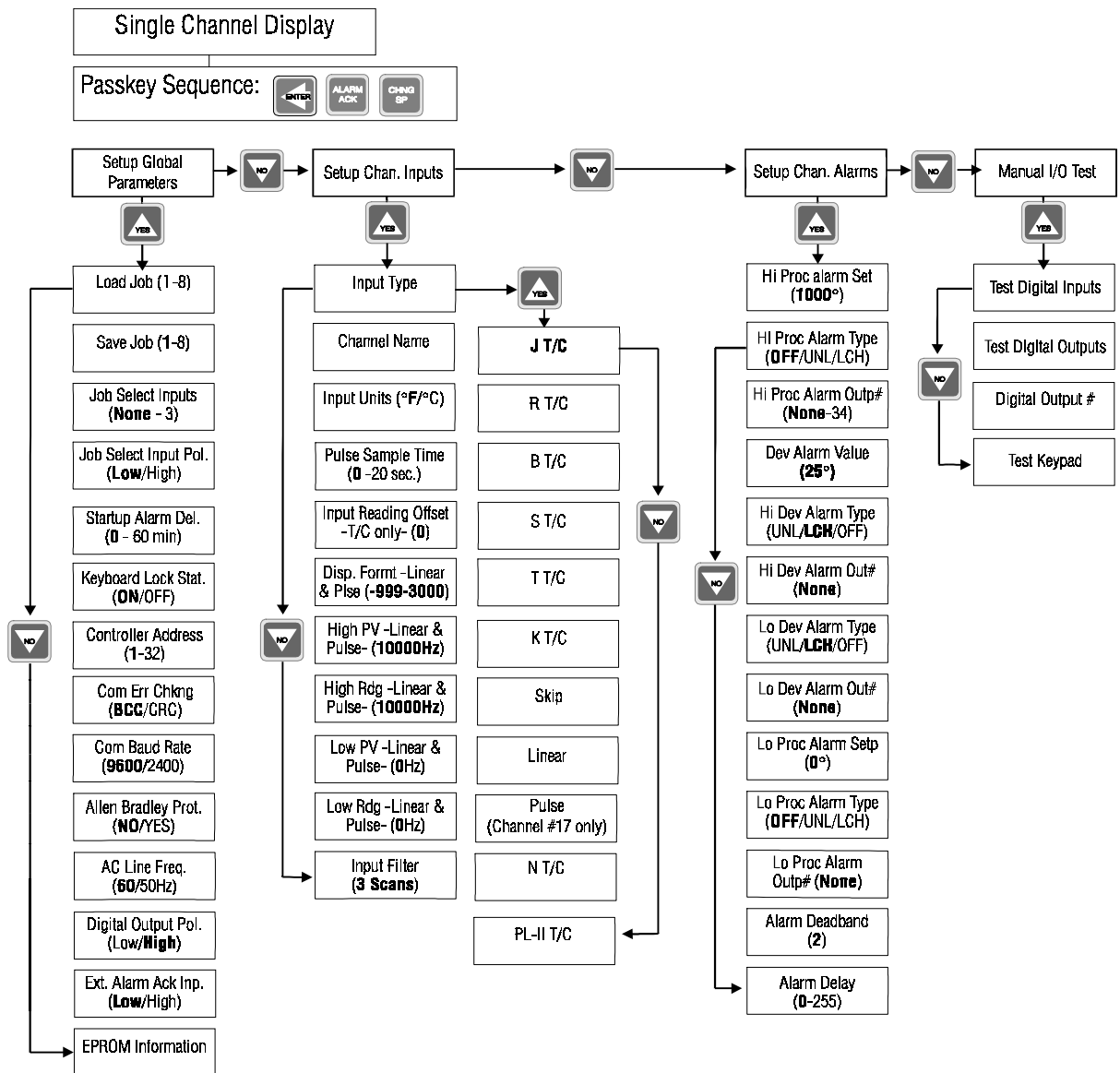

Default setting are shown in **BOLD** typeface.

Setup Global Parameters Menu

The setup global parameters menu looks like this.

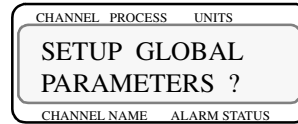

Load a Job



Selectable values: 1 to 8

The following parameters are loaded as part of a job:

- Setpoints and spread values
- Alarm functions (Off and Alarm), setpoints, high\low process setpoints, high\low deviation setpoints and deadband settings, and channel alarm delay.



WARNING

All current job settings will be overwritten if you select a job from memory. Save your current programming to a job number if you want to keep it..



Save Setup to Job

Use this menu to save job information for every channel, to one of eight jobs in the CAS battery-backed RAM.

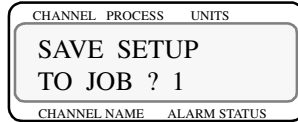

If you have not enabled the remote job control function, you will not be able to save a job. If you try it, you will get this message.



Job Select Inputs

Use this menu to run up to 8 jobs remotely. It lets you set the number of job select inputs. The CAS uses these inputs as a binary code that specifies the job number to run. The number of inputs you choose in this menu controls the number of jobs you can select remotely.

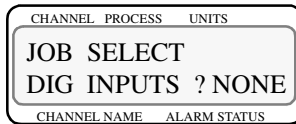

Below is the truth table that tells you which input states select which jobs.

Digital Input 3	Digital Input 2	Digital Input 1	Job #
F	F	F	1
F	F	T	2
F	T	F	3
F	T	T	4
T	F	F	5
T	F	T	6
T	T	F	7
T	T	T	8

Selectable values: 1, 2, or 3 inputs, or None. These choices have the following effect:

Setting	Enables
1 input	Jobs 1-2
2 inputs	Jobs 1-4
3 inputs	Jobs 1-8
None (no inputs)	Remote Select disabled

Job Select Input Polarity

This menu lets you set the polarity of the digital inputs used for job selection. You can set the Active state to closed (low) or open (high).

CHANNEL	PROCESS	UNITS
JOB SEL DIG INS		
ACTIVE ? LOW		
CHANNEL NAME	ALARM STATUS	

Selectable values: High or Low.

Startup Alarm Delay

Use this menu to set a startup delay for process and deviation alarms for all channels. The scanner does not report these alarm conditions for the specified number of minutes after the scanner powers up. (The scanner will always report failed sensor alarms, no matter what startup delay you set.)

CHANNEL	PROCESS	UNITS
STARTUP ALARM		
DELAY ? 0 MINS		
CHANNEL NAME	ALARM STATUS	

Selectable values: 0 - 60 minutes.

Keyboard Lock Status

This selection lets you lock the front panel operator function key, **Change SP**, so that pressing this key has no effect. If you want to use this function, turn off the Keyboard Lock.

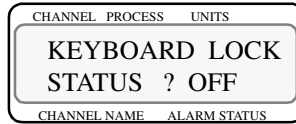

Selectable values: On or Off

Scanner Address

This menu allows you to set the CAS scanner address. The scanner address is used for multiple scanner communications on a single RS-485 cable, so each CAS must have a different address. Begin with address 1 for the first scanner and assign each subsequent scanner the next higher address.

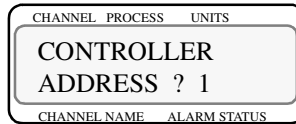

Selectable values: 1 - 32

Communications Error Checking

This selection allows you to set the data check algorithm used in the Anafaze communications protocol to Block Check Character (BCC) or to Cyclic Redundancy Check (CRC). CRC is a more secure error checking algorithm than BCC, but it requires more calculation time and slows the CAS communications. BCC ensures a high degree of communications integrity, so we recommend that you use BCC unless your application specifically requires CRC. Also, if using Anascan, ensure that the same error checking algorithm has been set through the 'scaninst' program.



Selectable values: BCC or CRC

Communications Baud Rate

This menu allows you to set the Communications Baud Rate. If using Anascan, ensure that that program has the same baud rate set through the 'scaninst' program.

CHANNEL	PROCESS	UNITS
COMMUNICATIONS BAUD RATE ? 9600		
CHANNEL NAME	ALARM STATUS	

Selectable values: 2400 or 9600

Allen-Bradley Protocol

This menu is located under the Setup Global Parameters main menu. It allows you to toggle the Allen-Bradley PLC Communications Protocol.

CHANNEL	PROCESS	UNITS
ALLEN BRADLEY PROTOCOL ? NO		
CHANNEL NAME	ALARM STATUS	

Selectable values: Yes or No

AC Line Frequency

This menu lets you configure the scanner to match an AC line frequency of 50 or 60 Hz. (This function is provided for international users who require 50 Hz lines.) Since the scanner reduces the effect of power line noise on the analog measurement by integrating the signal over the period of the AC line frequency, the scanner's noise rejection will suffer if the line frequency is not set correctly. Cycle power to enable this

CHANNEL	PROCESS	UNITS
AC LINE FREQ. ? 60 HERTZ		
CHANNEL NAME	ALARM STATUS	

change.

Selectable values: 50 or 60 Hz.

Digital Output Polarity

This menu lets you set the polarity of the digital outputs used for alarms.



Selectable values: High or Low

External Alarm Acknowledge Input

An external alarm reset or acknowledge button can be wired to the CAS at input #8. When activated, it performs the same function as if the "ALARM ACK" key was pressed.

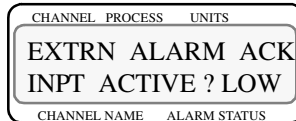

Selectable values: High or Low

EPROM Information

This view-only display shows the scanner's EPROM version and checksum.

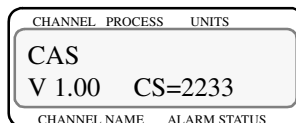

Setup Channel Inputs

The Setup Channel Input main menu lets you access menus which change parameters related to the channel input:

- Input type
- Input units
- Input scaling and calibration
- Input filtering

The next section explains how to use the Input menus to configure your scanner.



Input Type

This is the first menu of the Setup Channel Inputs menu. It lets you configure the input sensor for each channel as one of these input types:

- Thermocouple types (J, K, T, S, R,B, PL-II, and N).
- Linear inputs.
- Skip (an input type available for unused channels.) The scanning display doesn't show channels you've set to Skip.

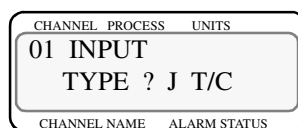

NOTE

If you set the input type to Skip, you won't see any of the other submenus in the Setup Channel Input menu. Channel #17 toggles between pulse and skip. If you set the input type to any thermocouple, you will see the Offset menu. If you set the input type to Linear, or you are editing the Pulse channel (#17), you will see the Input Scaling submenus.

Selectable values: The table shows the input types and ranges.

Input Type	Fahrenheit Range	Celcius Range
J	-350 to 1400	-212 to 815
K	-450 to 2500	-268 to 1371
T	-450 to 750	-268 to 399
S	0 to 3200	-18 to 1760
R	0 to 3210	-18 to 1765
B	+150 to 3200	+66 to 1760
PL-II	+50 to 2012	+10 to 1100
N	-450 to 2370	-268 to 1299
Pulse	0-2 KHz (Channel #17 only)	
Skip	Channel is not scanned or displayed	
Linear	See the Linear Scaling section (this chapter) and appendix.	

Pulse Sample Time

You can connect a digital pulse signal of up to 2 KHz to the scanner's pulse input. In this menu, you specify the pulse sample period. (This is the second menu of the Setup Channel Inputs menu for the pulse input channel only.) Every sample period, the number of pulses the scanner receives is divided by the sample time. The controller scales this number and uses it as the pulse channel's process variable.

CHANNEL	PROCESS	UNITS
05 INPUT PULSE		
SAMPLE TIME ? 1s		
CHANNEL NAME	ALARM STATUS	

Selectable values: 1 to 20 seconds

Channel Name

This menu lets you enter a channel name (up to seven characters) from this menu. If no name is entered, the CAS will default to the current channel number.

CHANNEL	PROCESS	UNITS
01 CHANNEL		
NAME ?		
CHANNEL NAME	ALARM STATUS	

Input Units

The Input Units menu lets you choose a three-character description of the channel's engineering units.

- Thermocouples can only be °F or °C.
- If you have selected a linear or pulse input type, you can choose any available character for each character position. For example, you can use GPM or PSI or % for a linear input's units.

CHANNEL	PROCESS	UNITS
02	INPUT	
	UNITS	? °F
CHANNEL NAME	ALARM STATUS	

The table below shows the character set for input units.

Input	Character Sets for Units
Thermocouple	°F or °C
Linear & Pulse	0-9, A-Z, %, /, °, space

Input Reading Offset

This menu lets you set an input reading offset function to make up for the input signal's inaccuracy at any given point. For example, at temperatures below 400 °F, a type J thermocouple may be inaccurate ("offset") by several degrees F. Use an independent thermocouple or your own calibration equipment to find the offset for your equipment. To correct for offset errors, change the factory default setting to a positive or negative value for the channel you are editing. (A positive value increases the reading and a negative value decreases it.)

CHANNEL	PROCESS	UNITS
01	INPUT READING	
	OFFSET	? 0° F
CHANNEL NAME	ALARM STATUS	

Selectable values: -300 to 300 for thermocouples



NOTE

If the input type is set to Linear, Pulse, or Skip, you will not see this menu.

Linear Scaling Menus

The linear scaling menus appear under the Setup Channel Inputs main menu. Linear scaling is available for linear and pulse inputs only. It lets you scale the "raw" input readings (readings in millivolts or hertz) to the engineering units of the process variable.



NOTE

The linear scaling menus will only be present if you set the channel's input type to Linear (or, for some menus, to Pulse).

For linear inputs, the input reading is in percent (-16.6 to 100%) representing the -10 to 60 mV input range of the CAS. For pulse inputs, the input reading is in hertz (cycles per second.) The scaling function is defined by two points on a conversion line, the high PV and the low PV. High PV is the high end of the input in engineering units, and the low PV is the low end. The engineering units of the process variable can be any arbitrary units.

The example below shows a high PV of 20 PSI and a low PV of 0 PSI. The high reading is the high end of the input signal (where 60mV = 100%).

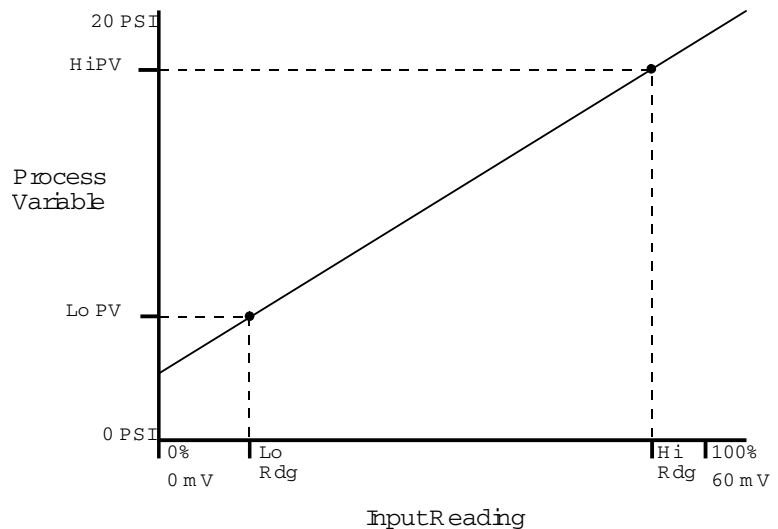

Before you enter the values that determine the two points for the conversion line, you must choose an appropriate display format. The CAS has six characters available for process variable display; select the setting with the desired number of decimal places before and after the decimal point. Use a display format that matches the range and resolution of the process variable. The display format you choose is used for the setpoint, alarms, deadband, and alarm deviation.

The PV (Process Variable) range for the scaled input is between the PV values that correspond to the 0% and 100% input readings. For the pulse input, it is between the 0 Hz and 2000 Hz readings. This PV range defines the limits for the setpoint and alarms, as shown here.

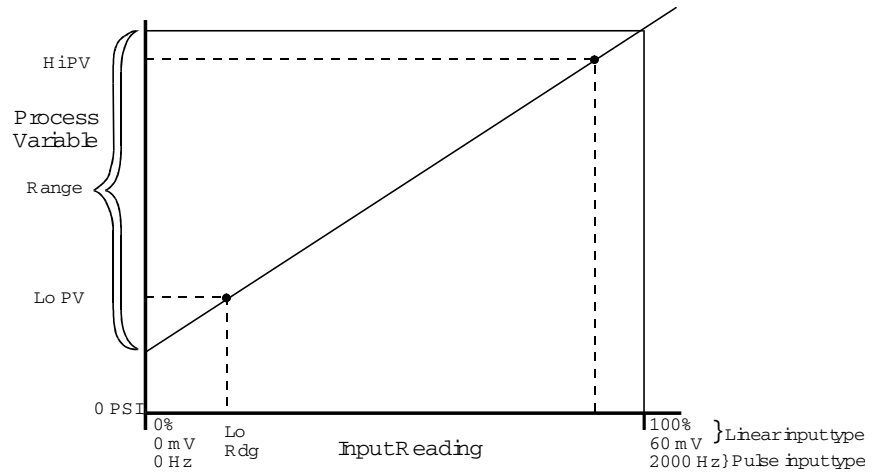

NOTE

For example linear scaling calculations, see *Appendix: Linear Scaling*.

Display Format

This menu lets you select a display format for a linear or pulse input. Choose a format appropriate for your input range and accuracy. (You will only see the Display Format menu if you are editing a linear or pulse input.)

CHANNEL	PROCESS	UNITS
01 DISP FORMAT ?		
-999 TO 3000		
CHANNEL NAME	ALARM STATUS	

The CAS has several available display formats; the display format you choose determines the default values for the rest of the linear scaling menus.

Display Format	Default High PV	Default Low PV
-9999 to +30000	10000	0
-999 to +3000	1000	0
-99.9 to +3000.0	1000.0	.0
-99.99 to +300.00	100.00	.00
-9.999 to +30.000	10.000	.000
-.9999 to +3.0000	1.0000	.0000

High Process Value

From this menu, you can enter a high process value. The high process value and the high reading value together define one of the points on the linear scaling function's conversion line.

CHANNEL	PROCESS	UNITS
01 INPUT SCALING		
HI PV ? 1000		
CHANNEL NAME	ALARM STATUS	

Selectable Values: The CAS displays the process value based on the table above.

High Reading

Use this menu to enter the input level that corresponds to the high process value you entered in the previous menu. (For linear inputs, the high reading is a percentage of the full scale input range. For pulse inputs, the high reading is expressed in Hz.)

The 100% full scale input value is 60 mV for the linear input type.

CHANNEL	PROCESS	UNITS
01 INPUT SCALING		
HI RDG ?		100.0
CHANNEL NAME	ALARM STATUS	

Selectable values: -99.9 to 999.9

Low Process Value

Use this menu to set a low process value for input scaling purposes. The low process value and the low reading value together define one of the points on the linear scaling function's conversion line.

CHANNEL	PROCESS	UNITS
01 INPUT SCALING		
LO PV ?		0° F
CHANNEL NAME	ALARM STATUS	

The default low PV is determined by the display format you selected (refer to *Display Format* table).

Low Reading

This menu appears under the Setup Channel Inputs main menu. Use it to enter the input level that corresponds to the low process value you selected in the previous menu. For linear inputs, the low reading is a percentage of the full scale input range; for pulse inputs, the low reading is expressed in Hz. The full input range for the linear input type is -10 to

CHANNEL	PROCESS	UNITS
01	INPUT SCALING	
LO RDG ?	0.0% FS	
CHANNEL NAME	ALARM STATUS	

60 mV. For pulse inputs, it is 0 to 2000 Hz.

Selectable values: -99.9 to 999.9

Input Filter

The CAS has two different types of input filter:

- A noise rejection filter that rejects high frequency input signal noise. This filter keeps a "trend log" of input readings. If a reading is outside the filter's "acceptance band", and later readings are within the acceptance band, the CAS ignores the anomalous reading. (The acceptance band for thermocouples is 5 degrees above and 5 degrees below the input reading. For linear inputs, it's 0.5% above and 0.5% below the input reading.) If later readings are also outside the acceptance band, the CAS accepts the anomalous reading and calculates a new acceptance band. (You cannot adjust this input filter.)
- A standard resistor-capacitor (RC) filter that lets you dampen the input response if inputs change unrealistically or change faster than the system can respond. If the input filter is enabled, the process variable responds to a step change by going to 2/3 of the actual value within the number of scans you set.

If all input channels are enabled, none of them set to SKIP, the CAS will scan 1.5 channels per second when set to 1 scan, and 4.5 channels per second when set to 3 scans.

CHANNEL	PROCESS	UNITS
01	INPUT FILTER ?	
	3 SCANS	
CHANNEL NAME	ALARM STATUS	

Selectable values: 0 to 255 scans

Setup Channel Alarms

The Setup Channel Alarms menu lets you access menus which change alarm function parameters for the current channel. The main alarms menu looks like this:



The CAS has three different kinds of alarms: failed sensor alarms, global alarms, and process alarms.

Failed Sensor Alarms

Failed sensor alarms alert you to T/C breaks.

Global Alarms

Global alarms occur when a channel alarm is active and unacknowledged, or when there are any unacknowledged failed sensor alarms. (If an alarm occurs, the CAS front panel displays an appropriate alarm code, see *Chapter 4: Using the CAS*.) Even if the alarm condition goes away, the global alarm stays on until you use the front panel **Alarm Ack** key (or ANASCAN) to acknowledge it.

Process Alarms

Process alarms include high and low deviation and high and low process alarms. You can set each of these alarms to Off, Latched or Unlatched, as shown here.

Function	Description
Off	No alarm
Latched	Alarm is only cleared if it is in a Non-Alarming state and the ALARM RESET key is pressed. If ALARM ACKNOWLEDGE has not been previously pressed, the ALARM RESET will acknowledge the global alarm as well.
Unlatched	Digital output activates on alarm, and deactivates when channel is in a Non-Alarming state. The ALARM ACK key must be pressed to shut off the global alarm.

- High process and high deviation alarms activate when the process variable goes above a value you set. They remain active until the process variable goes below that value minus the deadband. (See the diagram below.)
- Any digital output can be assigned to one or more process variable alarms. The output is active if any of its alarms are active. All alarm outputs are active Low or active High, depending on the global alarm output polarity setting.
- Low process and low deviation alarms activate when the process variable goes below a value you set. They remain active until the process variable goes above that value plus the deadband. (The diagram below shows these alarms.)

When the scanner powers up or the setpoint changes, deviation alarms do not activate until the process goes inside the deviation alarm band, preventing deviation alarms during a cold start. (High and low process alarms are always enabled.)

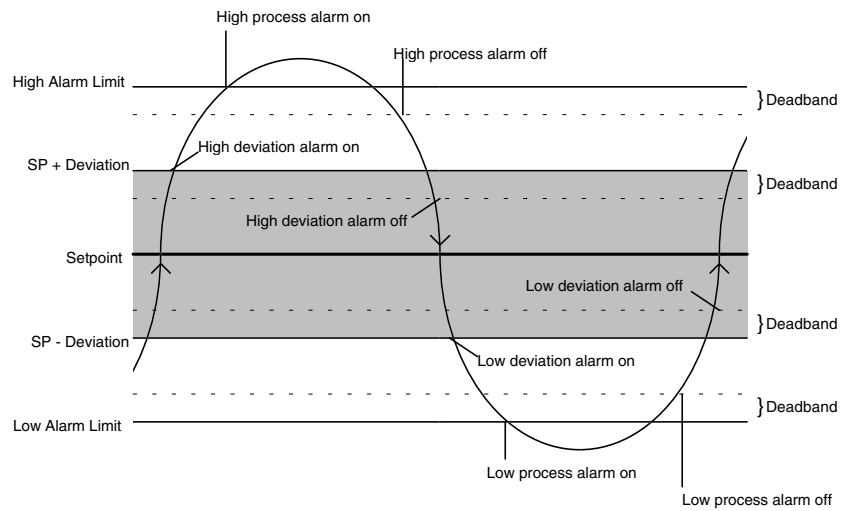

Use menus to set the following process alarm parameters for each channel:

- High and low process alarm type, setpoint, and digital output
- High and low deviation alarm type, deviation alarm value, and digital output
- Alarm deadband
- Alarm delay

The setpoints, deviation alarm values, and deadband all use the same decimal format as the channel's process variable.

Alarm Delay

You can set the CAS to delay normal alarm detection and alarm reporting. There are two kinds of alarm delay:

- Startup alarm delay delays detection of process alarms (but not failed sensor alarms) for all channels for a time period you set in the **Setup Global Parameters main menu**.
- Channel alarm delay delays failed sensor alarms and process alarms for one channel until the alarm condition is continuously present for longer than the channel alarm delay time you set.



NOTE

Failed sensor alarms are detected at startup. They are affected by the channel alarm delay, not the startup alarm delay time.

High Process Alarm Setpoint

This menu lets you select the setpoint (temperature or other value within the scaled sensor range) at which the high process alarm activates. The high process alarm activates when the process variable (PV) goes above the high process setpoint. It deactivates when the PV goes below the high process setpoint minus the deadband value, if you have set a deadband value.

CHANNEL	PROCESS	UNITS
01	HI PROC ALARM	
	SETPT ?	1000° F
CHANNEL NAME	ALARM STATUS	

Selectable values: Any point within the scaled sensor range

High Process Alarm Type

This menu lets you turn off the high process alarm or set it to one of the alarm functions. (See the previous description for an explanation of these choices).

CHANNEL	PROCESS	UNITS
01	HI PROC ALARM	
	TYPE ?	OFF
CHANNEL NAME	ALARM STATUS	

Selectable values: Off, Latched, Unlatched

High Process Alarm Output Number

This menu lets you choose the digital output that activates when the channel is in high process alarm. You can use this output to activate a second alarm horn or buzzer.

CHANNEL	PROCESS	UNITS
01	HI PROC ALARM	
	OUTPUT ?	NONE
CHANNEL NAME	ALARM STATUS	

Selectable values: 1 to 34, None



NOTE

All digital outputs are combined. Therefore you can assign more than one alarm to the same output number, and that output will be On if any of those alarms is On.

Deviation Alarm Value

This menu lets you set the deviation bandwidth, a positive and negative alarm point relative to the setpoint. If the setpoint changes, the alarm points also change. You can assign a separate digital output to the high and low deviation alarm setpoints.

CHANNEL	PROCESS	UNITS
01	DEV ALARM	
	VALUE ?	25° F
CHANNEL NAME	ALARM STATUS	

Selectable values: 0 to 255, 25.5, 2.55, .255 or .0255, depending on the way you set up the Input menus.

High Deviation Alarm Type

This menu lets you disable the high deviation alarm function or set it to the alarm functions. (The high deviation alarm activates if the process value (PV) rises above the deviation band value, and remains active until the PV goes below the deviation band value minus the deadband value.)

CHANNEL	PROCESS	UNITS
01	HI DEV ALARM	
	TYPE ?	LATCHED
CHANNEL NAME	ALARM STATUS	

Selectable values: Latched, Unlatched, or Off.

High Deviation Alarm Output Number

This menu assigns a digital output which activates when the channel is in high deviation alarm. The digital output only activates if you have set the high deviation alarm to On.

CHANNEL	PROCESS	UNITS
01	HI DEV ALARM	
	OUTPUT ?	NONE
CHANNEL NAME	ALARM STATUS	

Selectable values: 1 to 34, None



NOTE

All digital outputs are combined. Therefore, you can assign more than one alarm to the same output number, and that output will be On if any of those alarms are On.

Low Deviation Alarm Type

This menu turns off the low deviation alarm or set it to the alarm function.

CHANNEL	PROCESS	UNITS
01	LO DEV ALARM	
	TYPE ?	LATCHED
CHANNEL NAME	ALARM STATUS	

Selectable values: Off, Latched, or Unlatched

Low Deviation Alarm Output Number

This menu is used to assign a digital output that activates when the channel is in low deviation alarm.

CHANNEL	PROCESS	UNITS
01	LO DEV ALARM	
	OUTPUT ?	NONE
CHANNEL NAME	ALARM STATUS	

Selectable values: 1 to 34, None



NOTE

All digital outputs are OR'd together (combined). Therefore you can assign more than one alarm to the same output number, and that output will be On if any of those alarms is On.

Low Process Alarm Setpoint

This menu is used to set a low process alarm setpoint. (The low process alarm activates when the process variable goes below the low process alarm setpoint. It deactivates when the process variable goes above the low process alarm setpoint plus the deadband.)

CHANNEL	PROCESS	UNITS
01	LO PROC ALARM	
	SETPT ?	0
CHANNEL NAME	ALARM STATUS	

Selectable values: Any value within the input sensor's range

Low Process Alarm Type

This menu lets you turn off the low process alarm or set it to the alarm function.

CHANNEL	PROCESS	UNITS
01	LO PROC ALARM	
	TYPE ?	OFF
CHANNEL NAME	ALARM STATUS	

Selectable values: Off, Latched, Unlatched

Low Process Alarm Output Number

This menu lets you assign the digital output that activates when the channel is in low process alarm.

CHANNEL	PROCESS	UNITS
01	LO PROC ALARM	
	OUTPUT ?	NONE
CHANNEL NAME	ALARM STATUS	

Selectable values: NONE, 1 to 34



NOTE

All digital outputs are combined. Therefore you can assign more than one alarm to the same output number, and that output will be On if any of those alarms is On.

Alarm Deadband

This menu lets you set an alarm deadband. This deadband value applies to the high process, low process, high deviation, and low deviation alarms for the channel you are editing.

The alarm deadband sets the hysteresis of the alarm action which is used to avoid intermittent alarms as the PV returns to a normal state.

CHANNEL	PROCESS	UNITS
01	ALARM DEAD	
	BAND ?	2° C
CHANNEL NAME	ALARM STATUS	

Selectable values: 0 to 255, 25.5, 2.55, .255, or .0255, depending on your input menu setup.

Alarm Delay

This menu sets a channel alarm delay. There are two types of alarm delay: the startup alarm delay and channel alarm delay. Startup alarm delay (which you can set in the **Setup Global Parameters** main menu) delays process alarms (but not failed sensor alarms) for all channels for a specified time after the CAS powers up.

The channel alarm delay, in contrast, is set separately for each channel. It delays failed sensor and process alarms until the alarm condition has been continuously present for longer than the alarm delay time. (Failed sensor alarms are not subject to the startup alarm delay, but they are affected by the channel's alarm delay during the startup alarm delay period.)

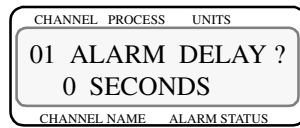

Selectable values: 0 to 255 seconds

Manual I/O Test

Press **Yes** at this prompt to see menus which can help you test the digital inputs, digital outputs and the CAS' keypad.

CHANNEL	PROCESS	UNITS
MANUAL I/O TEST ?		
CHANNEL NAME	ALARM STATUS	

Digital Input Testing

This is a read-only menu that shows the logic state of the 8 digital inputs as H (High- the input is at 5 volts or is not connected) or L (Low- the input is at zero volts). Inputs 1 to 8 are displayed from left to right. Since inputs are pulled High when they are not connected, test an input by shorting it to controller common and making sure this menu shows the correct state for that input.

CHANNEL	PROCESS	UNITS
DIGITAL INPUTS HLLHHHH		
CHANNEL NAME	ALARM STATUS	

Digital Output Selection

This menu lets you select one of the digital alarm outputs to test in the next menu.

CHANNEL	PROCESS	UNITS
TEST DIGITAL OUTPUT ? 34		
CHANNEL NAME	ALARM STATUS	

Digital Output Test

This menu lets you manually toggle a digital output On or Off to test it. (Select the output to test in the previous menu.) On may be Low or High depending on the digital output polarity you set. (All outputs are set to Off when you exit this menu.)

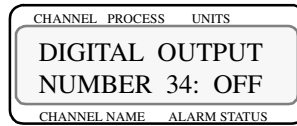

Press **Yes** or **No** to toggle the output state between On and Off.

Keypad Test

This menu lets you test the keypad. Press any key on the keypad to test the response. The CAS will display the name of the key you have pressed.

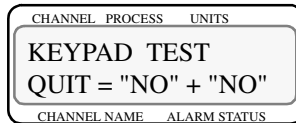

Troubleshooting

The next few sections describe general troubleshooting for the CAS. Later sections describe specific procedures, like checking an input, changing the EPROM, and testing the device.

First, Check your Installation

Please bear in mind that, even in stand-alone systems, the CAS is only part of your system. Often, what appears to be a problem with the CAS is really a problem with other equipment- so check these things first:

- Scanner is installed correctly. (See Chapter 2: Installation for help.)
- Inputs, like thermocouples, are installed correctly and are working.

Second, Replace Unit

If you are certain that the scanner is installed correctly, you can try replacing the CAS with a spare CAS. If the spare unit works correctly, then the problem is specific to the CAS you replaced.



WARNING

If the scanner wasn't installed correctly; for instance, if you have shorted sensor inputs to high voltage lines or a transformer is shorted out, and you replace the CAS with a spare unit, the spare unit will break, and you'll need to send both units to Watlow Anafaze for repair. Therefore, make sure you have checked the installation before replacing the unit.

If you need to update the CAS Erasable Programmable Read-Only Memory (EPROM), please refer to the third section, Changing the EPROM.

Manual System Reset

If the instructions in this manual tell you to perform a "No Key Reset", please do the following:

1. Power down the unit.
2. Press and hold the No key on the front panel. Power up the unit.



NOTE

A No key reset clears the CAS memory and resets its parameters to their default values. If you have a stand-alone system, there is no way to recover your original parameters. If you have a computer-supervised system with ANASCAN, you can save a copy of your parameters to a job file.



WARNING

Do not attempt to repair the CAS yourself. If the troubleshooting procedures in this chapter do not solve your system's problems, call the Technical Services department for additional troubleshooting help. If you need to return the unit to Watlow Anafaze for testing and repair, Customer Service will issue you an RMA number- see Returning the Unit below.

Returning the Unit

If you need to return the CAS, please call the Watlow Anafaze Customer Service department at (408)-724-3800 for a Returned Materials Authorization (RMA) number. The RMA number helps us track your equipment and return it to you as soon as possible.

Troubleshooting Stand-Alone Systems

The CAS is only part of a control system- be sure to check other parts of the system, like thermocouples, before you assume that the unit is broken. To check inputs and outputs, follow these procedures.

Checking an Analog Input

To check any input except the pulse input, follow these steps:

1. Disconnect the sensor wiring.
2. Set the input sensor to type J T/C from the Setup menus.
3. Place a short across the input.

The process variable should indicate ambient temperature. If it does not, call Watlow Anafaze for an RMA number and return the unit to Watlow Anafaze for repair.

To check thermocouple inputs, remove the thermocouple leads and use an ohm meter to measure between the In+ and In- terminals of TB1. Thermocouple inputs should not read above 200 ohms.

Checking Digital I/O

The following steps will help you test digital inputs and outputs.

TB-50 Test

1. Plug in the power supply, if you have not already done so.
2. Measure the +5Vdc supply at the TB-50:
 - A. Connect the voltmeter's Common lead to TB-50 screw terminal #3.
 - B. Connect the voltmeter's Power lead to TB-50 screw terminal #1. The voltage should be 4.75 to 5.25 Vdc.

Digital Output Test

Test digital outputs this way:

1. Connect a 500 ohm to 100 Kohm resistor between the +5V pin (TB-50 screw terminal 1) and the output pin you want to test.
2. Connect the Common lead to the output pin.
3. Connect the voltmeter positive lead to the +5V pin.
4. If you are testing a digital output, use the Manual I/O Test menu to turn the output on and off. (See Chapter 4: Setup for information on the Manual I/O Test menu.)

Digital Input Test

Test digital inputs this way:

1. Go to the digital input test menu (under the Manual I/O Test main menu). This menu shows whether the digital inputs are H (high, or open) or L (Low, or closed).
2. Attach a wire to the terminal of the digital input you want to test.
 - When the wire is connected only to the digital input terminal, the digital input test menu should show that the input is H (High, or open).
 - When you connect the wire to logic ground (TB-50 pin 3), the digital input test menu should show that the input is L (Low, or closed).

Checking Computer Supervised Systems

Four elements must work properly in a computer supervised system that uses an IBM-compatible computer and ANASCAN:

- The CAS.
- The computer and its RS-232 or RS-485 serial interface.
- The RS-232 or RS-485 communications line.
- The computer's software.

For CAS troubleshooting, disconnect the communications line from the computer before you follow the troubleshooting steps explained in the previous sections. Troubleshooting for the computer and communications are explained in the sections below.

Computer Problems

If you are having computer or serial interface problems, check the following:

1. Make sure you are using DOS 5.0 or a later version of DOS.
2. Check the communications interface, cables, and connections. Make sure the serial interface is set according to the manufacturer's instructions.
 - To test an RS-232 interface, buy an RS-232 troubleshooter from Radio Shack or an equivalent supplier. Attach the troubleshooter between the CAS and the computer. When ANASCAN sends data to the CAS, the troubleshooter's TX LED should blink. When ANASCAN receives data from the CAS, the RX LED should blink.
 - You can also connect an oscilloscope to the transmit or receive line to see whether data is being sent or received. If the serial interface does not function, contact your computer service representative.



NOTE

Most communications problems are due to incorrect wiring or from incorrectly setting the communication parameters. Therefore, check the wiring and communications settings first.

If you have more than one CAS, or you are using more than 50 feet of communications wiring, you must use RS-485 communications. Otherwise, you can use RS-232 communications. The CAS is configured for RS-232 communications when it is shipped. If you are using RS-485 communications, you must set the internal RS232/RS485 selection jumpers to the correct position. (See *Installation*, for information about changing jumpers.)

From the setup menus, make sure that the communications parameters (address, error checking and baud rate) are set correctly for each CAS in your system.

Every controller must have a separate address, starting with 1 and increasing by 1 for each controller.

The error checking method and baud rate must be set the same way in the controller's setup menus and in ANASCAN.

Ground Loops

On some computers, the RS-232 common wire is tied to earth ground. Since the CAS ground is also tied to earth ground, this arrangement creates a ground loop which may affect communications and other CAS functions. To avoid ground loops, either use an optically isolated communications adapter or disconnect the CAS from earth ground and tie a .1 μ F capacitor from CAS DC common to earth ground.

Software Problems

ANASCAN

Consult the ANASCAN Software Operating Manual for help with ANASCAN.

User-Written Software

If you don't want to use ANASCAN as your software interface to the CAS, you are responsible for the correct operation of the software you buy or write. You can request technical documentation from Watlow Anafaze if you want to write your own software. Watlow Anafaze will answer any technical questions that arise during your software development process, but Watlow Anafaze does not otherwise support user software in any way.

Changing the EPROM

Changing the EPROM involves minor mechanical disassembly and reassembly of the CAS, but you don't need any soldering or electrical expertise. The only tools you need are a Phillips head screwdriver and a small flathead screwdriver.



NOTE

If you change the EPROM, you must perform a No Key Reset for the EPROM change to take effect. A No Key Reset changes all controller parameters back to their default values, so you must reenter the desired values from ANASCAN or from the front panel after you change the EPROM.

1. Power down the CAS. Be sure to take antistatic precautions.
2. Remove the four screws from the sides of the unit's front panel.

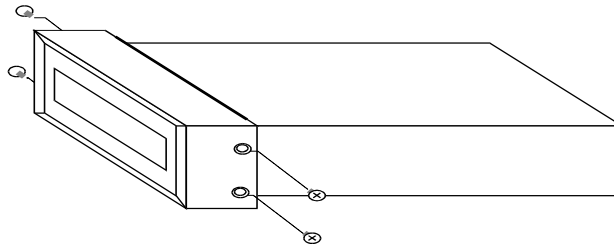

3. Remove the electronics assembly from the case, as shown below.

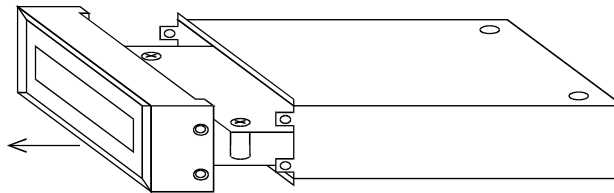

4. Unscrew the four screws at the corners of the top board and carefully unplug this board to access the bottom board (processor board), as shown below.

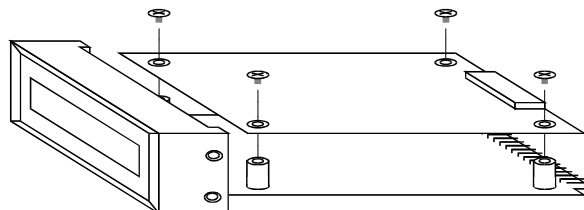

5. Find the installed EPROM. This is a 28 pin socketed chip which should have an Watlow Anafaze label on top of it. (If there is no label, a small window will be visible in the middle of the top of the chip.) Do not confuse the EPROM with the RAM; the RAM also has 28 pins, but it is in a high profile socket, and it does not have a label or a window. (The component designation U2 is printed on the processor board next to the EPROM socket.) The next figure shows the EPROM and RAM chip.

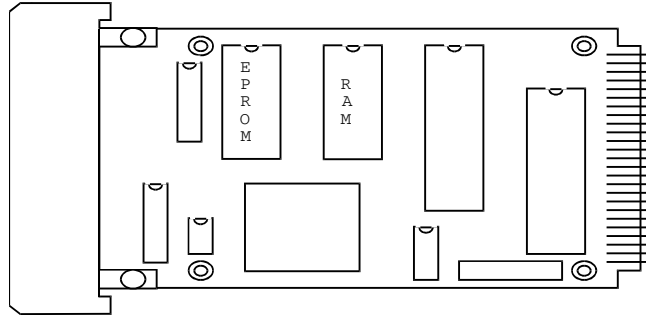

6. Remove the existing EPROM from its socket by prying it out with a small flathead screwdriver, as shown below.

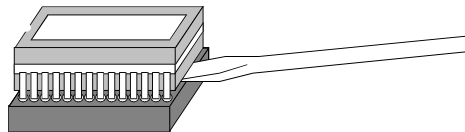

7. The EPROM is shipped with its legs bent at an angle that best fits its packaging. Bend the legs slightly so that the legs line up with the holes in the EPROM socket. Don't try to bend the legs one at a time; instead, gently press the legs against a flat surface until they're at a 90-degree angle to the EPROM body, as shown below.

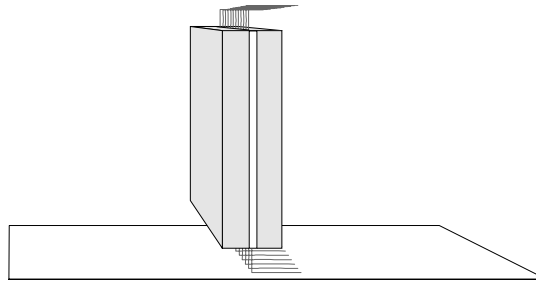

8. Carefully insert the new EPROM into the EPROM socket. Make sure that the chip is oriented so that its notch faces the same way as the part outline on the board.
9. Reverse steps 2 through 4 to reassemble the unit.
10. Do a No key reset to reinitialize the battery backed RAM. You must perform a No key reset for the unit to operate properly. (To do a No key reset, power down the CAS. Then press the No key and power up the unit.)

Appendix: Linear Scaling

Examples

Example 1

Situation

A pressure sensor that generates a 4-20 milliamp signal is connected to the CAS. The specifications of the sensor state that it generates 4 milliamps at 0.0 PSI and 20 mA at 50.0 PSI.

Setup

The sensor is connected to a channel input set up with a resistor scaling network to produce 60 millivolts at 20 mA. (See the Inputs section of Chapter 2: Installation for more information on scaling networks.)

The sensor measures PSI in tenths, so the appropriate display format is -999.9 to +3000.0.

This table shows the input readings.

PV Displayed	Sensor Input	Reading (%FS)
50.0 psi	20	100%
0.0	4	$100\% \times (4\text{ma}/20\text{ma}) = 20\%$

The scaling values are therefore:

Parameter	Low Value	High Value
Process Value (PV)	0.0 psi	50.0 psi
Input Reading (RDG)	20.0	100.0

Example 2

Situation

A flow sensor connected to the CAS measures the flow in a pipe. The sensor generates a 0-5V signal. The sensor's output depends on its installation. Independent calibration measurements of the flow in the pipe indicate that the sensor generates 0.5 volts at three gallons per minute (GPM) and 4.75 volts at 65 GPM. The calibration instruments are precise to ± 1 gallon per minute.

Setup

The sensor is connected to a channel input set up with a resistor voltage divider network to produce 60 millivolts at 5 volts. (See the Inputs section of the Installation chapter for information on scaling networks.)

The calibrating instrument is precise to ± 1 gallon per minute, so the appropriate display format is -999 to +3000.

This table shows the input readings.

PV Displayed	Sensor Input	Reading (%FS)
65 GPM	4.75	$(4.75 \text{ V} / 5.00 \text{ V}) \times 100\% = 95\%$
3 GPM	0.5	$(0.5 \text{ V} / 5.00 \text{ V}) \times 100\% = 10\%$

The scaling values are therefore:

Parameter	Low Value	High Value
Process Value (PV)	3 GPM	65 GPM
Input Reading	10.0	95.0

Example 3

Situation

A pulse encoder which measures the movement of a conveyor is connected to the CAS. The encoder generates 900 pulses for every inch the conveyor moves. You want to measure conveyor speed in feet per minute (f/m).

Setup

The encoder input is connected to the pulse input. An one second sample time gives adequate resolution of the conveyor's speed.

The resolution is:

$$\frac{1 \text{ pulse}}{1 \text{ second}} \times \frac{60 \text{ seconds}}{1 \text{ minute}} \times \frac{1 \text{ inch}}{900 \text{ pulses}} \times \frac{1 \text{ foot}}{12 \text{ inches}} = 0.006 \text{ f/m}$$

so a display format of -99.99 to +300.00 is appropriate.

The input readings are as follows.

At the maximum pulse rate of the CAS (2000 Hz):

$$\frac{2000 \text{ pulses}}{1 \text{ second}} \times \frac{60 \text{ seconds}}{1 \text{ minute}} \times \frac{1 \text{ inch}}{900 \text{ pulses}} \times \frac{1 \text{ foot}}{12 \text{ inches}} = 11.11 \text{ f/m}$$

At zero hertz, the input reading will be 0.00 f/m.

Therefore, the scaling values are:

Parameter	Low Value	High Value
Process Value (PV)	0 f/m	11.11 f/m
Input Reading (RDG)	0 Hz	2000 Hz

Glossary

A

AC

See Alternating Current.

AC Line Frequency

The frequency of the AC power line measured in Hertz (Hz), usually 50 or 60 Hz.

Accuracy

Closeness between the value indicated by a measuring instrument and a physical constant or known standards.

Action

The response of an output when the process variable is changed. See also Direct action, Reverse action.

Address

A numerical identifier for a controller when used in computer communications.

Alarm

A signal that indicates that the process has exceeded or fallen below a certain range around the setpoint. For example, an alarm may indicate that a process is too hot or too cold. See also:

- Deviation Alarm
- Failed Sensor Alarm
- Global Alarm
- High Deviation Alarm
- High Process Alarm
- Loop Alarm
- Low Deviation Alarm
- Low Process Alarm

Alarm Delay

The lag time before an alarm is activated.

Alternating Current (AC)

An electric current that reverses at regular intervals, and alternates positive and negative values.

Ambient Temperature

The temperature of the air or other medium that surrounds the components of a thermal system.

American Wire Gauge (AWG)

A standard of the dimensional characteristics of wire used to conduct electrical current or signals. AWG is identical to the Brown and Sharpe (B&S) wire gauge.

Ammeter

An instrument that measures the magnitude of an electric current.

Ampere (Amp)

A unit that defines the rate of flow of electricity (current) in the circuit. Units are one coulomb (6.25 x 10¹⁸ electrons) per second.

Analog Output

A continuously variable signal that is used to represent a value, such as the process value or setpoint value. Typical hardware configurations are 0-20mA, 4-20mA or 0-5 Vdc.

Automatic Mode

A feature that allows the controller to set PID control outputs in response to the Process Variable (PV) and the setpoint.

Autotune

A feature that automatically sets temperature control PID values to match a particular thermal system.

B

Bandwidth

A symmetrical region above and below the setpoint in which proportional control occurs.

Baud Rate

The rate of information transfer in serial communications, measured in bits per second.

Block Check Character (BCC)

A serial communications error checking method. An acceptable method for most applications, BCC is the default method. See CRC.

Bumpless Transfer

A smooth transition from Auto (closed loop) to Manual (open loop) operation. The control output does not change during the transfer.

C

Calibration

The comparison of a measuring device (an unknown) against an equal or better standard.

Celsius (Centigrade)

Formerly known as Centigrade. A temperature scale in which water freezes at 0°C and boils at 100°C at standard atmospheric pressure. The formula for conversion to the Fahrenheit scale is: °F=(1.8x°C)+32.

Central Processing Unit (CPU)

The unit of a computing system that includes the circuits controlling the interpretation of instructions and their execution.

Circuit

Any closed path for electrical current. A configuration of electrically or electromagnetically-connected components or devices.

Closed Loop

A control system that uses a sensor to measure a process variable and makes decisions based on that feedback.

Cold Junction

Connection point between thermocouple metals and the electronic instrument.

Common Mode Rejection Ratio

The ability of an instrument to reject electrical noise, with relation to ground, from a common voltage. Usually expressed in decibels (dB).

Communications

The use of digital computer messages to link components.

See Serial Communications.

See Baud Rate.

Control Action

The response of the PID control output relative to the error between the process variable and the setpoint. For reverse action (usually heating), as the process decreases below the setpoint the output increases. For direct action (usually cooling), as the process increases above the setpoint, the output increases.

Control Mode

The type of action that a controller uses. For example, On/Off, time proportioning, PID, Automatic or manual, and combinations of these.

Current

The rate of flow of electricity. The unit of measure is the ampere (A).

1 ampere = 1 coulomb per second.

Cycle Time

The time required for a controller to complete one on-off-on cycle. It is usually expressed in seconds.

Cyclic Redundancy Check (CRC)

An error checking method in communications. It provides a high level of data security but is more difficult to implement than Block Check Character (BCC).

See Block Check Character.

D

Data Logging

A method of recording a process variable over a period of time. Used to review process performance.

Deadband

The range through which a variation of the input produces no noticeable change in the output. In the deadband, specific conditions can be placed on control output actions. Operators select the deadband. It is usually above the heating proportional band and below the cooling proportional band.

Default Parameters

The programmed instructions that are permanently stored in the microprocessor software.

Derivative Control (D)

The last term in the PID algorithm. Action that anticipated the rate of change of the process, and compensates to minimize overshoot and undershoot. Derivative control is an instantaneous change of the control output in the same direction as the proportional error. This is caused by a change in the process variable (PV) that decreases over the time of the derivative (TD). The TD is in units of seconds.

Deutsche Industrial Norms (DIN)

A set of technical, scientific and dimensional standards developed in Germany. Many DIN standards have worldwide recognition.

Deviation Alarm

Warns that a process has exceeded or fallen below a certain range around the setpoint.

Digital to Analog Converter (DAC)

A device that converts a numerical input signal to a signal that is proportional to the input in some way.

Direct Action

An output control action in which an increase in the process variable, causes an increase in the output. Cooling applications usually use direct action.

Direct Current (DC)

An electric current that flows in one direction.

Distributed Zero Crossing (DZC)

A form of digital output control. Similar to burst fire.

E

Earth Ground

A metal rod, usually copper, that provides an electrical path to the earth, to prevent or reduce the risk of electrical shock.

Electrical Noise

See Noise.

Electromagnetic Interference (EMI)

Electrical and magnetic noise imposed on a system. There are many possible causes, such as switching ac power on inside the sine wave. EMI can interfere with the operation of controls and other devices.

Electrical-Mechanical Relays

See Relay, electromechanical.

Emissivity

The ratio of radiation emitted from a surface compared to radiation emitted from a blackbody at the same temperature.

Engineering Units

Selectable units of measure, such as degrees Celsius and Fahrenheit, pounds per square inch, newtons per meter, gallons per minute, liters per minute, cubic feet per minute or cubic meters per minute.

EPROM

Erasable Programmable, Read-Only Memory inside the controller.

Error

The difference between the correct or desired value and the actual value.

F

Fahrenheit

The temperature scale that sets the freezing point of water at 32°F and its boiling point at 212°F at standard atmospheric pressure. The formula for conversion to Celsius is: $^{\circ}\text{C} = 5/9 (^{\circ}\text{F} - 32^{\circ}\text{F})$.

Failed Sensor Alarm

Warns that an input sensor no longer produces a valid signal. For example, when there are thermocouple breaks, infrared problems or resistance temperature detector (RTD) open or short failures.

Filter

Filters are used to handle various electrical noise problems.

Digital Filter (DF) — A filter that allows the response of a system when inputs change unrealistically or too fast. Equivalent to a standard resistor-capacitor (RC) filter

Digital Adaptive Filter — A filter that rejects high frequency input signal noise (noise spikes).

Heat/Cool Output Filter — A filter that slows the change in the response of the heat or cool output. The output responds to a step change by going to approximately 2/3 its final value within the numbers of scans that are set.

Frequency

The number of cycles over a specified period of time, usually measured in cycles per second. Also referred to as Hertz (Hz). The reciprocal is called the period.

G

Gain

The amount of amplification used in an electrical circuit. Gain can also refer to the Proportional (P) mode of PID.

Global Alarm

Alarm associated with a global digital output that is cleared directly from a controller or through a user interface.

Global Digital Outputs

A pre-selected digital output for each specific alarm that alerts the operator to shut down critical processes when an alarm condition occurs.

Ground

An electrical line with the same electrical potential as the surrounding earth. Electrical systems are usually grounded to protect people and equipment from shocks due to malfunctions. Also referred to a "safety ground".

H

Hertz(Hz)

Frequency, measured in cycles per second.

High Deviation Alarm

Warns that the process is above setpoint, but below the high process variable. It can be used as either an alarm or control function.

High Power

(As defined by ANAFAZE) Any voltage above 24 VAC or Vdc and any current level above 50 mAac or mAdc.

High Process Alarm

A signal that is tied to a set maximum value that can be used as either an alarm or control function.

High Process Variable (PV)

See Process Variable (PV).

High Reading

An input level that corresponds to the high process value. For linear inputs, the high reading is a percentage of the full scale input range. For pulse inputs, the high reading is expressed in cycles per second (Hz).

I

Infrared

A region of the electromagnetic spectrum with wavelengths ranging from one to 1,000 microns. These wavelengths are most suited for radiant heating and infrared (noncontact) temperature sensing.

Input

Process variable information that is supplied to the instrument.

Input Scaling

The ability to scale input readings (readings in percent of full scale) to the engineering units of the process variable.

Input Type

The signal type that is connected to an input, such as thermocouple, RTD, linear or process.

Integral Control (I)

Control action that automatically eliminates offset, or droop, between setpoint and actual process temperature.

See Auto-reset.

J

Job

A set of operating conditions for a process that can be stored and recalled in a controller's memory. also called a Recipe.

Junction

The point where two dissimilar metal conductors join to form a thermocouple.

L

Lag

The delay between the output of a signal and the response of the instrument to which the signal is sent.

Linear Input

A process input that represents a straight line function.

Linearity

The deviation in response from an expected or theoretical straight line value for instruments and transducers. also called Linearity Error.

Liquid Crystal Display (LCD)

A type of digital display made of a material that changes reflectance or transmittance when an electrical field is applied to it.

Load

The electrical demand of a process, expressed in power (watts), current (amps), or resistance (ohms). The item or substance that is to be heated or cooled.

Loop Alarm

Any alarm system that includes high and low process, deviation band, deadband, digital outputs, and auxiliary control outputs.

Low Deviation Alarm

Warns that the process is below the setpoint, but above the low process variable. It can be used as either an alarm or control function.

Low Process Alarm

A signal that is tied to a set minimum value that can be used as either an alarm or control function.

Low Reading

An input level corresponding to the low process value. For linear inputs, the low reading is a percentage of the full scale input range. For pulse inputs, the low reading is expressed in cycles per second (Hz).

M

Manual Mode

A selectable mode that has no automatic control aspects. The operator sets output levels.

Manual Reset

See Reset.

Milliampere (mA)

One thousandth of an ampere.

N

No Key Reset

A method for resetting the controller's memory (for instance, after an EPROM change).

Noise

Unwanted electrical signals that usually produce signal interference in sensors and sensor circuits. See Electromagnetic Interference.

Noise Suppression

The use of components to reduce electrical interference that is caused by making or breaking electrical contact, or by inductors.

Non Linear

Through ANAFAZE software, the Non Linear field sets the system to linear control, or to one of two non linear control options. Input 0 for Linear, 1 or 2 for non linear.

O

Offset

The difference in temperature between the setpoint and the actual process temperature. Offset is the error in the process variable that is typical of proportional-only control.

On/Off Control

A method of control that turns the output full on until setpoint is reached, and then off until the process error exceeds the hysteresis.

Open Loop

A control system with no sensory feedback.

Operator Menus

The menus accessible from the front panel of a controller. These menus allow operators to set or change various control actions or features.

Optical Isolation

Two electronic networks that are connected through an LED (Light Emitting Diode) and a photoelectric receiver. There is no electrical continuity between the two networks.

Output

Control signal action in response to the difference between setpoint and process variable.

Output Type

The form of PID control output, such as Time Proportioning, Distributed Zero Crossing, SDAC, or Analog. Also the description of the electrical hardware that makes up the output.

Overshoot

The amount by which a process variable exceeds the setpoint before it stabilizes.

P

Panel Lock

A feature that prevents operation of the front panel by unauthorized people.

PID

Proportional, Integral, Derivative. A control mode with three functions:

Proportional action dampens the system response, Integral corrects for droops, and Derivative prevents overshoot and undershoot.

Polarity

The electrical quality of having two opposite poles, one positive and one negative. Polarity determines the direction in which a current tends to flow.

Process Variable

The parameter that is controlled or measured. Typical examples are temperature, relative humidity, pressure, flow, fluid level, events, etc. The high process variable is the highest value of the process range, expressed in engineering units. The low process variable is the lowest value of the process range.

Proportional (P)

Output effort proportional to the error from setpoint. For example, if the proportional band is 20° and the process is 10° below the setpoint, the heat proportioned effort is 50%. The lower the PB value, the higher the gain.

Proportional Band (PB)

A range in which the proportioning function of the control is active. Expressed in units, degrees or percent of span.

See PID.

Proportional Control

A control using only the P (proportional) value of PID control.

Pulse Input

Digital pulse signals from devices, such as optical encoders.

R**Ramp**

A programmed increase in the temperature of a setpoint system.

Range

The area between two limits in which a quantity or value is measured. It is usually described in terms of lower and upper limits.

Recipe

See Job.

Reflection Compensation Mode

A control feature that automatically corrects the reading from a sensor.

Relay

A switching device.

Electromechanical Relay — A power switching device that completes or interrupts a circuit by physically moving electrical contacts into contact with each other. Not recommended for PID control.

Solid State Relay (SSR) — A switching device with no moving parts that completes or interrupts a circuit electrically.

Reset

Control action that automatically eliminates offset or droop between setpoint and actual process temperature.

See also Integral.

Automatic Reset — The integral function of a PI or PID temperature controller that adjusts the process temperature to the setpoint after the system stabilizes. The inverse of integral.

Automatic Power Reset — A feature in latching limit controls that

Resistance

Opposition to the flow of electric current, measured in ohms.

Resistance Temperature Detector (RTD)

A sensor that uses the resistance temperature characteristic to measure temperature. There are two basic types of RTDs: the wire RTD, which is usually made of platinum, and the thermistor which is made of a semiconductor material. The wire RTD is a positive temperature coefficient sensor only, while the thermistor can have either a negative or positive temperature coefficient.

Reverse Action

An output control action in which an increase in the process variable causes a decrease in the output. Heating applications usually use reverse action.

RTD

See Resistance Temperature Detector.

S**Serial Communications**

A method of transmitting information between devices by sending all bits serially over a single communication channel.

RS-232—An Electronics Industries of America (EIA) standard for interface between data terminal equipment and data communications equipment for serial binary data interchange. This is usually for communications over a short distance (50 feet or less) and to a single device.

RS-485—An Electronics Industries of America (EIA) standard for electrical characteristics of generators and receivers for use in balanced digital multipoint systems. This is usually used to communicate with multiple devices over a common cable or where distances over 50 feet are required.

Setpoint (SP)

The desired value programmed into a controller. For example, the temperature at which a system is to be maintained.

Shield

A metallic foil or braided wire layer surrounding conductors that is designed to prevent electrostatic or electromagnetic interference from external sources.

Signal

Any electrical transmittance that conveys information.

Solid State Relay (SSR)

See Relay, Solid State.

Span

The difference between the lower and upper limits of a range expressed in the same units as the range.

Spread

In heat/cool applications, the +/- difference between heat and cool. Also known as process deadband.

See deadband.

Stability

The ability of a device to maintain a constant output with the application of a constant input.

T

T/C Extension Wire

A grade of wire used between the measuring junction and the reference junction of a thermocouple. Extension wire and thermocouple wire have similar properties, but extension wire is less costly.

TD (Timed Derivative)

The derivative function.

Thermistor

A temperature-sensing device made of semiconductor material that exhibits a large change in resistance for a small change in temperature. Thermistors usually have negative temperature coefficients, although they are also available with positive temperature coefficients.

Thermocouple (T/C)

A temperature sensing device made by joining two dissimilar metals. This junction produces an electrical voltage in proportion to the difference in temperature between the hot junction (sensing junction) and the lead wire connection to the instrument (cold junction).

TI (Timed Integral)

The Integral term.

Transmitter

A device that transmits temperature data from either a thermocouple or RTD by way of a two-wire loop. The loop has an external power supply. The transmitter acts as a variable resistor with respect to its input signal. Transmitters are desirable when long lead or extension wires produce unacceptable signal degradation.

U

Upscale Break Protection

A form of break detection for burned-out thermocouples. Signals the operator that the thermocouple has burned out.

Undershoot

The amount by which a process variable falls below the setpoint before it stabilizes.

V

Volt (V)

The unit of measure for electrical potential, voltage or electromotive force (EMF).

See Voltage.

Voltage (V)

The difference in electrical potential between two points in a circuit. It's the push or pressure behind current flow through a circuit. One volt (V) is the difference in potential required to move one coulomb of charge between two points in a circuit, consuming one joule of energy. In other words, one volt (V) is equal to one ampere of current (I) flowing through one ohm of resistance (R), or $V=IR$.

Z

Zero Cross

Action that provides output switching only at or near the zero-voltage crossing points of the ac sine wave.

